

The Harman Kardon Model CH140

Manual 91A

HIGH FIDELITY CASSETTE DECK/TUNER

Technical Manual



CH140

harman/kardon

240 Crossways Park West, Woodbury, N.Y. 11797
1112-H15291A5 P-088503 1450 Printed in Japan

SPECIFICATIONS

● FM SECTION

	Nominal	Limit
Tuning Range	87.5MHz ~ 107.9MHz	
Usable Sensitivity	12dBf	≤ 18dBf
Quieting Sensitivity		
Mono	17dBf	≤ 23dBf
Stereo	35dBf	≤ 40dBf
Signal to Noise Ratio		
Mono	72dB	≥ 66dB
Stereo	65dB	≥ 60dB
IF Rejection (88.1MHz)	100dB	≥ 90dB
Image Rejection (98.1MHz)	60dB	≥ 55dB
AM Suppression	50dB	≥ 44dB
Capture Ratio	1.5dB	≤ 3dB
Selectivity (± 400kHz)	70dB	≥ 60dB
Distortion (Stereo)		
(65dBf, 100%)	0.22%	≤ 0.4%
Frequency Response		
(+0, -3dB)	20Hz ~ 15kHz	
MPX Separation at 1kHz	44dB	≥ 35dB
Output Level (75kHz dev.)	775mV	± 3dB

● AM SECTION

Tuning Range	530kHz ~ 1620kHz
Signal to Noise Ratio	50dB ≥ 45dB
IF Rejection (600kHz)	100dB ≥ 90dB
Image Rejection (1400kHz)	55dB ≥ 50dB
Selectivity (± 9kHz)	50dB ≥ 45dB

● AUDIO SECTION

	Nominal	Limit
Tone Control Action		
Bass (50Hz)	11dB	± 1.5dB
Treble (10kHz)	11dB	± 1.5dB
Output Impedance	500Ω	

● CASSETTE TAPE DECK SECTION

Wow and Flutter	0.1% ≤ 0.2%
Tape Speed (4.75cm/sec.)	+1% ≤ +3% -1%
FF and REW Time	
(for C-60 tape)	125sec. ≤ 150sec.
Signal to Noise Ratio (LN Position)	
Dolby* NR Off	55dB ≥ 50dB
Dolby NR On	64dB ≥ 58dB
Distortion	1% ≤ 2%
Frequency Response	20Hz ~ 20kHz
Separation	40dB ≥ 35dB
Crosstalk	70dB ≥ 60dB
Output Level (Volume Max.)	610mV ± 3dB

This specification is the target of servicing. But, there is a case that the specification is not applicable to the measurement condition and instrument.

Specifications and components subject to change without notice. Overall performance will be maintained or improved.

*Dolby noise reduction manufactured under license from Dolby Laboratories Licensing Corporation. "Dolby" and the double-D symbol are trademarks of Dolby Laboratories Licensing Corporation.

DISASSEMBLY PROCEDURES (REFER TO PAGES 10 AND 13)

① CASSETTE TAPE PLAYER MECHANICAL ASSEMBLY (104) REMOVAL

1. Remove 4 screws (A) and then remove the Bracket (173).
2. Pull out the Fader Knob (158).
3. Remove 4 screws (B) and then remove the Center Panel Assembly (101).
4. Remove 4 screws (C) and then remove the Cassette Tape Player Mechanical Assembly (104) with the NAB AMP, MSS/Mecha Control and Dolby P.C. Boards (PCB-2, PCB-3 and PCB-9) and the Brackets (171 and 168). Also, disconnect the lead wires connected to the Main P.C. Board (PCB-1).
5. Disconnect the lead wires connected to the Dolby P.C. Board (PCB-9).
6. Remove 2 screws (D) and then remove the Dolby P.C. Board (PCB-9).
7. Disconnect the lead wires connected to the NAB AMP P.C. Board (PCB-2).
8. Remove 2 screws (E) and then remove the NAB AMP P.C. Board (PCB-2).

9. Disconnect the lead wires connected to the MSS/Mecha control P.C. Board (PCB-3).
10. Remove the screw (F) and then remove the MSS/Mecha control P.C. Board (PCB-3).
11. Remove 4 screws (G) and then remove the Cassette Tape Player Mechanical Assembly (104) from the Bracket (171).

② MAIN P.C. BOARD (PCB-1) REMOVAL

1. Remove 4 screws (H) and then remove the Bracket (177) and the Insulator (183).
2. Remove the Center Panel Assembly (101). (Refer to step ①-2 and 3.)
3. Pull out 9 Push Buttons (153).
4. Remove the screw (I) and then remove the Bracket (169).
5. Remove 6 screws (J) and then remove the Main P.C. Board (PCB-1) with the Buffer AMP P.C. Board (PCB-4). Also, disconnect the lead wires connected to the Main P.C. Board (PCB-1).

ALIGNMENT PROCEDURES (REFER TO PAGES 7 ~ 12)

■ ELECTRICAL ADJUSTMENT

1. Before adjustment

- Connect a 14V power supply to the Power Supply Lead (+ACC, +B and GND).
- Since head magnetization, dust accumulations, etc. are likely to introduce errors in the various characteristics, it is very important that the heads are properly demag-netized and cleaned before commencing any adjustment, particularly frequency response and head azimuth adjustment.

2. Instruments required

- Low frequency oscillator
- AC VTVM or dual channel AC VTVM
- Oscilloscope
- Wow/flutter meter
- Frequency counter

3. Test tapes

- Dolby NR level adjustment MTT-150 or TCC-130
- Azimuth adjustment TCC-153

4. General conditions (unless otherwise noted).

CONTROLS AND SWITCHES	SETTINGS
Balance	center
Bass	center
Treble	center
Fader	center
Dolby NR	off
70 μ sec./LOCAL-DX	off
MS/MONO	off

5. Standard load

- Connect the resistor (10k Ω) and the capacitor (1000pF) to the line output.
- Standard output 200mV

6. Dummy antenna

- FM : IHF

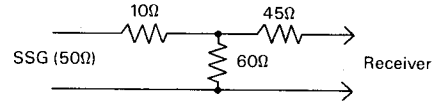

Measurement at receiver input level in term of available power.

- AM : IEC

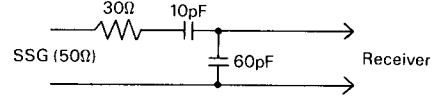

Measurement at SSG terminal voltage (open).

■ TUNER SECTION

Step	Alignment	Connection Equipments	Mode	Measurement Frequency	Station display	Adjustment	For
1	Standard frequency	●Connect the Frequency Counter to TP4 (+) and ground (-).		98.3MHz	98.3MHz	TC701	109MHz \pm 30Hz
2	IF	●Connect the FM Signal Generator (1kHz 100% modulation) to the Antenna jack through the FM dummy antenna. ●Connect Oscilloscope, Distortion Meter and AC Voltmeter to the line output.	FM	98.1MHz (17dBf)	98.1MHz	VR101	Maximum output
3				98.1MHz (6dBf)	98.1MHz	IFT (built in TU701)	Maximum output
4				98.1MHz (65dBf)	98.1MHz	T101	Adjust so that the same and maximum output is obtained on both Low Frequency side and High Frequency side when the FM Signal Generator is shifted to both sides by the same amount from 98.1MHz (65dBf).
5				98.1MHz (65dBf)	98.1MHz	T102	Minimum distortion
6	Free run frequency	●Connect the Frequency Counter to TP3 (+) and ground (-).	FM	98.1MHz (65dBf) (unmodulation)	98.1MHz	VR153	76kHz \pm 50Hz
7	Sub-carrier rejection	●Connect the Stereo Modulator to FM Signal Generator. Connect the FM Signal Generator to the Antenna jack through the FM dummy antenna.	Stereo FM	98.1MHz (65dBf)	98.1MHz	VR152	Minimum output at 19kHz pilot signal only by stereo Modulator.
8	Separation	●Connect Oscilloscope, Distortion Meter and AC Voltmeter to the line output.	Stereo FM	98.1MHz (65dBf)	98.1MHz	VR151	Adjust so that the right channel output becomes minimum when only the left channel of the Stereo Modulator is modulated.
						VR151	Adjust so that the left channel output becomes minimum when only the right channel of the Stereo Modulator is modulated.
9				98.1MHz (30dBf)	98.1MHz	VR101	Adjust so that the separation becomes 10dB.
10				Repeat step 8.			
11				Repeat step 9 for optimum sensitivity.			

■ TAPE SECTION

Step	Alignment	Connection Equipments	Test Tape	Mode	Adjustment	For
1	Dolby NR level	●Connect the AC VTVM or dual channel AC VTVM to TP1 (Lch), TP2 (Rch) and ground.	MTT-150 or TCC-130	PB	VR251 (Lch) VR252 (Rch)	- 10dBm
2	Azimuth		TCC-153	PB	Azimuth screw	Maximum output (Refer to the next page for the details.)

HEAD REPLACEMENT AND ADJUSTMENT

1 Head replacement

1. Remove the Cassette Tape Player Mechanical Assembly from the main unit according to the disassembly procedure.
2. Remove the **A** portion of the Loading Link. (See Fig.1)
3. Remove the 2 screws **B** in Fig.1 and remove the Frame Assembly, Cassette Pack Guide and Guide Arm Assembly, and then replace the head.

2 Head height confirmation

1. Install the M-300 Head Gauge plate.
2. Release the Lock Link to allow the head and pinch roller to lift up (in the same state as when playing back).
3. Check to make sure that the adjustment chip does not contact the tape guide of the head. (See Fig.2)

- After the head replacement and height confirmation, clean the head and pinch roller where the tape runs against and then install them.

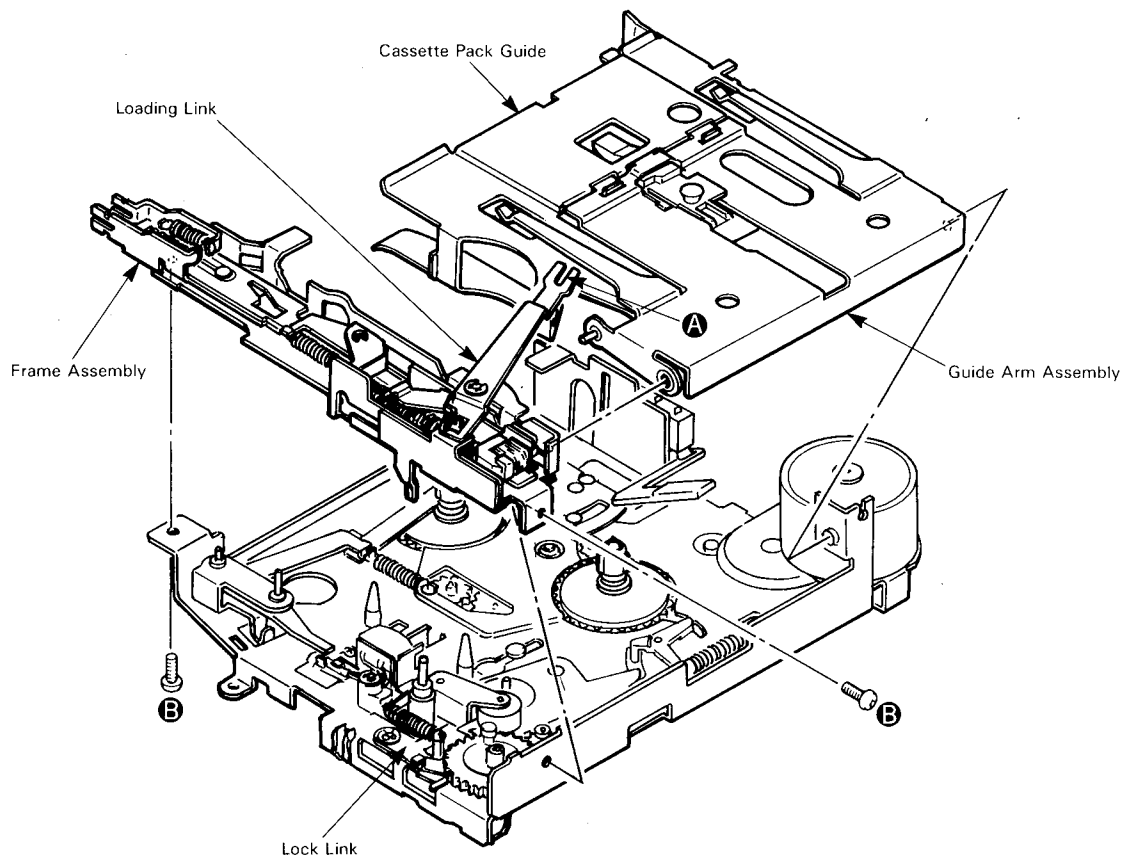

Fig. 1

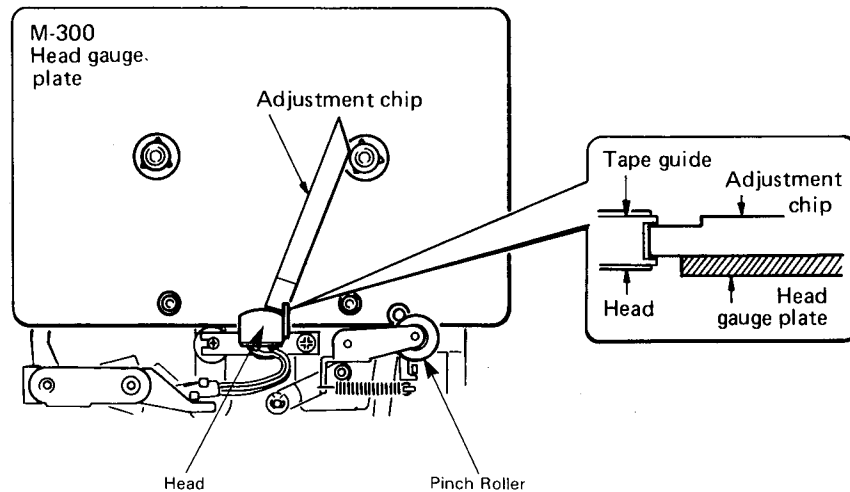

Fig.2

3 Azimuth adjustment

- Adjust the azimuth upon completion of the main unit assembly (with both upper and lower covers installed).
1. Connect the power source (DC14V) to the power supply lead to make the main unit ready to operate.

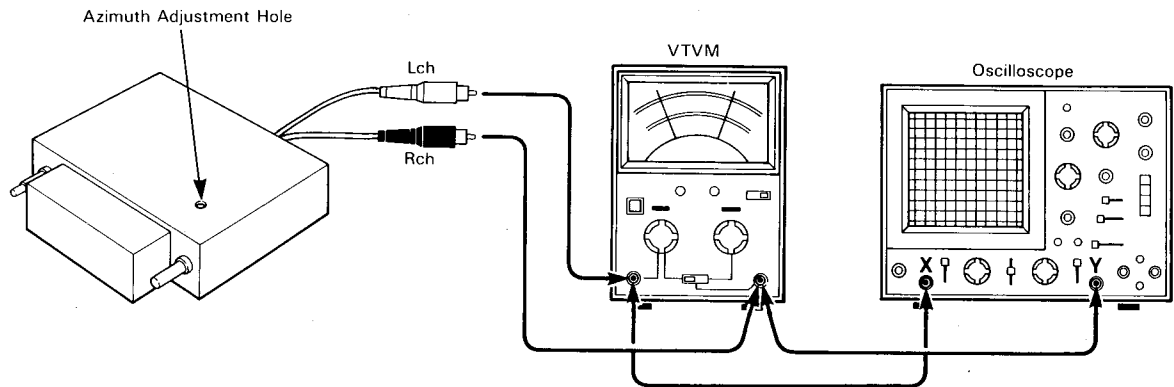

Fig.3

2. Connect the dual channel AC VTVM and 2ch oscilloscope to the line output.
3. Play back the test tape (TCC-153) and adjust the azimuth screw with a phillips screwdriver inserted into the azimuth adjustment hole in the upper cover. Adjust so that the same maximum VTVM value is indicated on both left channel and right channel and also so that the phase is within $0^\circ \pm 90^\circ$ while watching the lissajous's waveform.

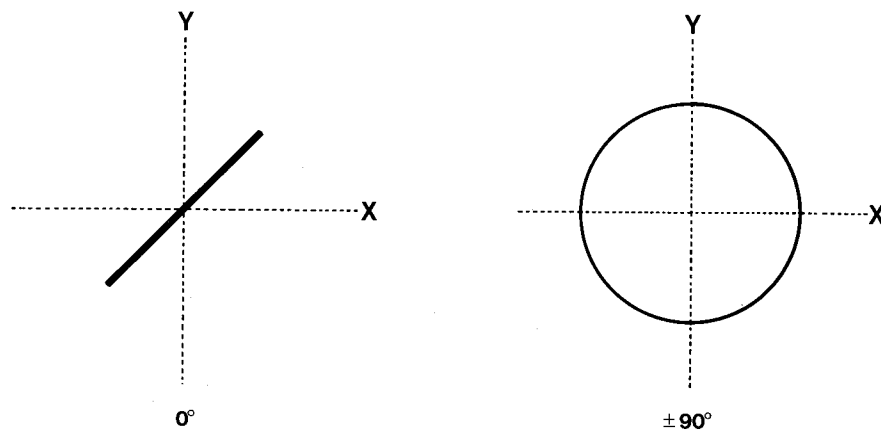

Fig.4

CIRCUIT DESCRIPTION

1. Signal path

• FM signal

The FM signal is mixed with the output of the local oscillator in the super heterodyne circuit in the front end (TU701) and is output from 8 pin as a 10.7MHz intermediate frequency signal (IF signal). After passing through the Q101 and ceramic filter (CF101), the IF signal is amplified in the sextuple IF amplifiers in the IC101, detected in the quadrature and output. The ignition noise of the signal is suppressed in the FM noise canceller (IC151) and the signal is sent to the IC152, where it is demodulated into the stereo signal and fed to the audio amplifier.

• AM signal

The AM signal is high frequency amplified (RF AMP), mixed (MIXER), intermediate frequency amplified (IF AMP) and then demodulated into the audio signal in the IC (LA1135) in the AM section (TU702). This signal is output through 10 pin of the AM section and fed to 2 pin of the IC152.

2. Muting circuit

• Muting during tuning

One of the muting signal emitted from 17 pin of the IC701 actuates the switch in the IC501 to cut off the signal from the tuner. The other is input to 2 pin of the IC361 (IC for muting) and makes Q409 (front Lch), Q411 (rear Lch), Q410 (front Rch) and Q412 (rear Rch) all low level by making 4 pin low level and Q362 high level. Thus the muting is completed.

• Muting while operating tape

One of the TG CONT signals actuates the switch in the IC501 to cut off the playback signal and the signal from the tuner. Then as in muting during tuning, it makes Q409 (front Lch), Q411 (rear Lch), Q410 (front Rch) and Q412 (rear Rch) low level and thus muting is completed. The other makes Q265 (Lch) and Q266 (Rch) low level to perform muting.

3. Playback signal

The playback signal taken out of the playback head is amplified in the playback amplifier. Then it is elongated in the Dolby circuit of the IC301 when the dolby switch is ON and fed to the audio amplifier. When the dolby switch is OFF, it passes through the IC301 and fed to the audio amplifier.

BLOCK DIAGRAM

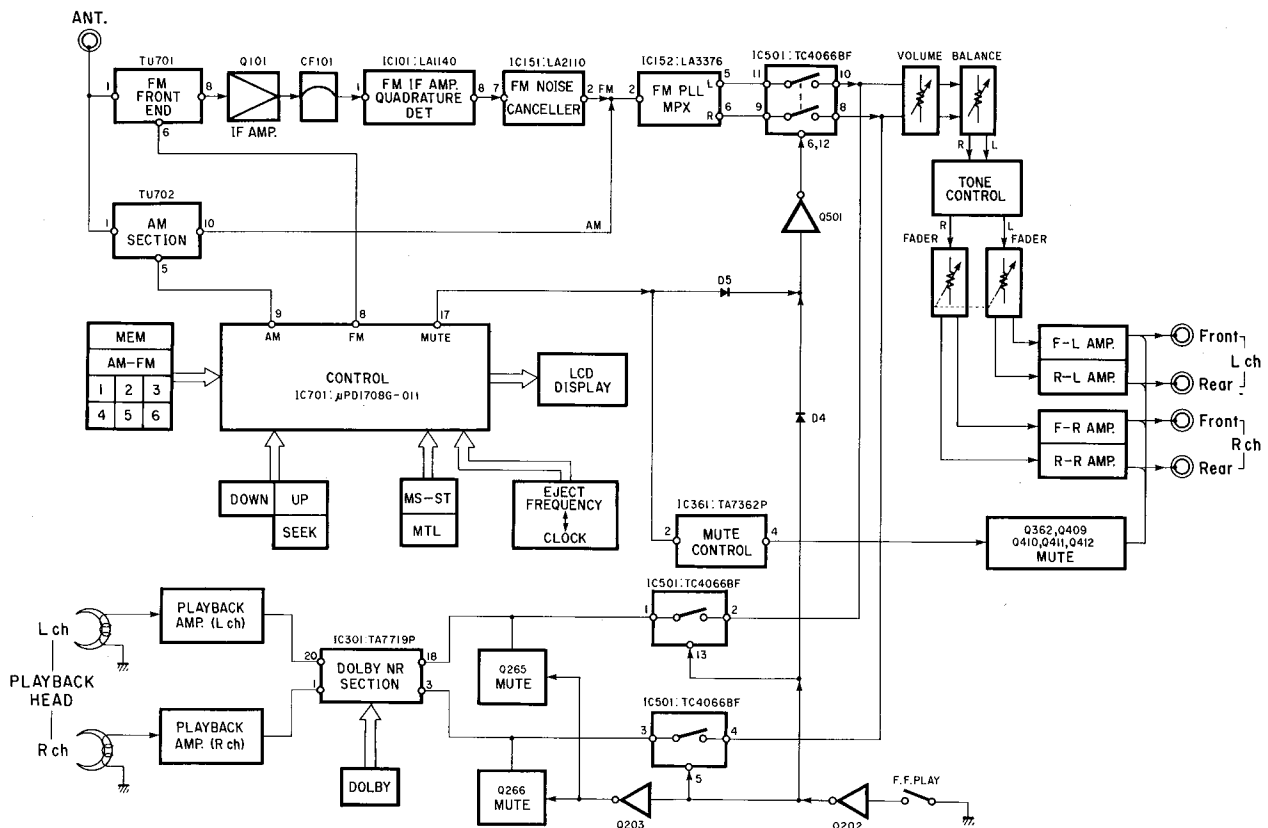

SCHEMATIC DIAGRAM (1)

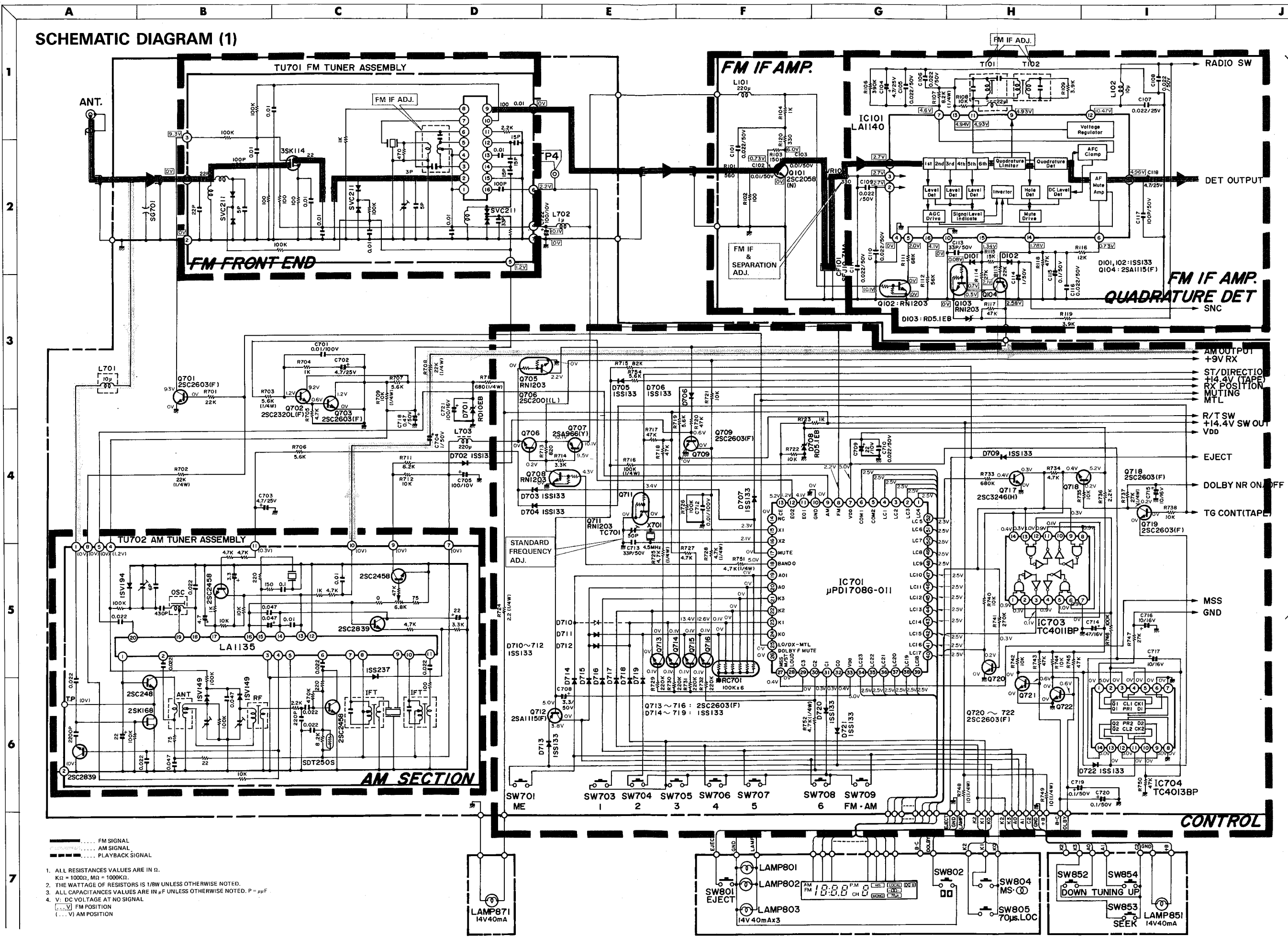

SCHEMATIC DIAGRAM (1)

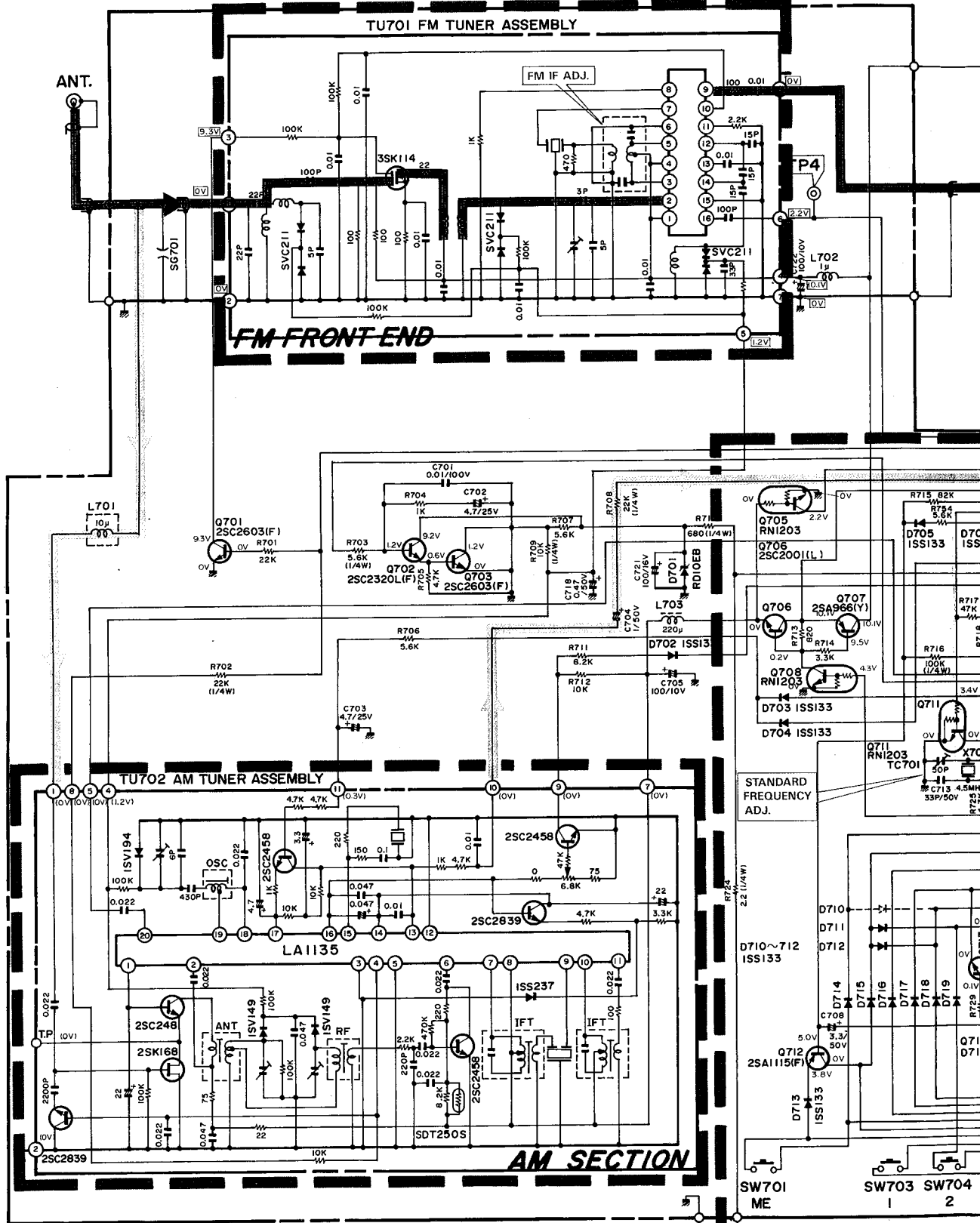

- FM SIGNAL
 - - - - - AM SIGNAL
 - PLAYBACK SIGNAL
1. ALL RESISTANCE VALUES ARE IN Ω .
K Ω = 1000 Ω , M Ω = 1000K Ω .
 2. THE WATTAGE OF RESISTORS IS 1/8W UNLESS OTHERWISE NOTED.
 3. ALL CAPACITANCE VALUES ARE IN μ F UNLESS OTHERWISE NOTED. P = pF
 4. V: DC VOLTAGE AT NO SIGNAL
 - [V] FM POSITION
 - [... V] AM POSITION

F G H I J

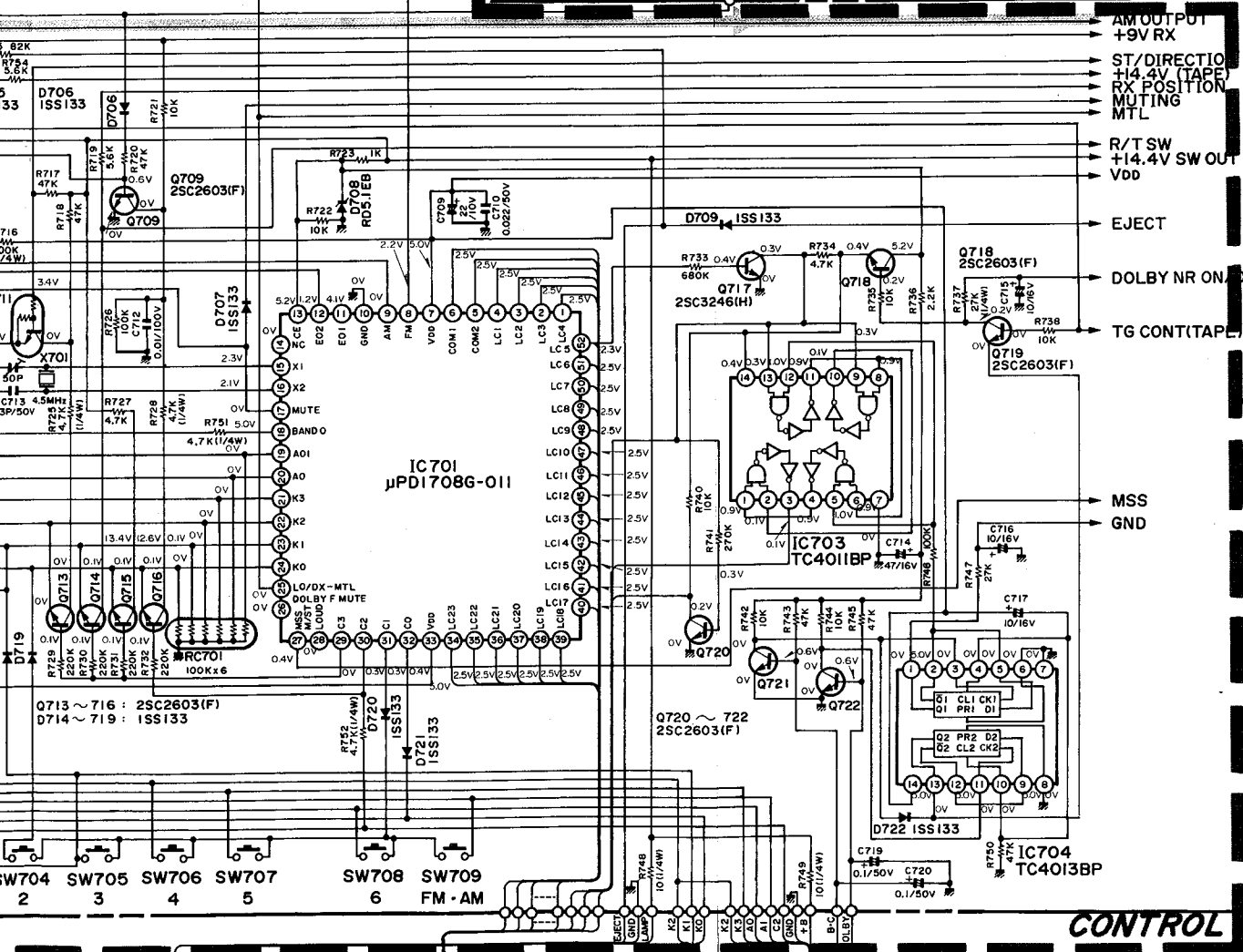
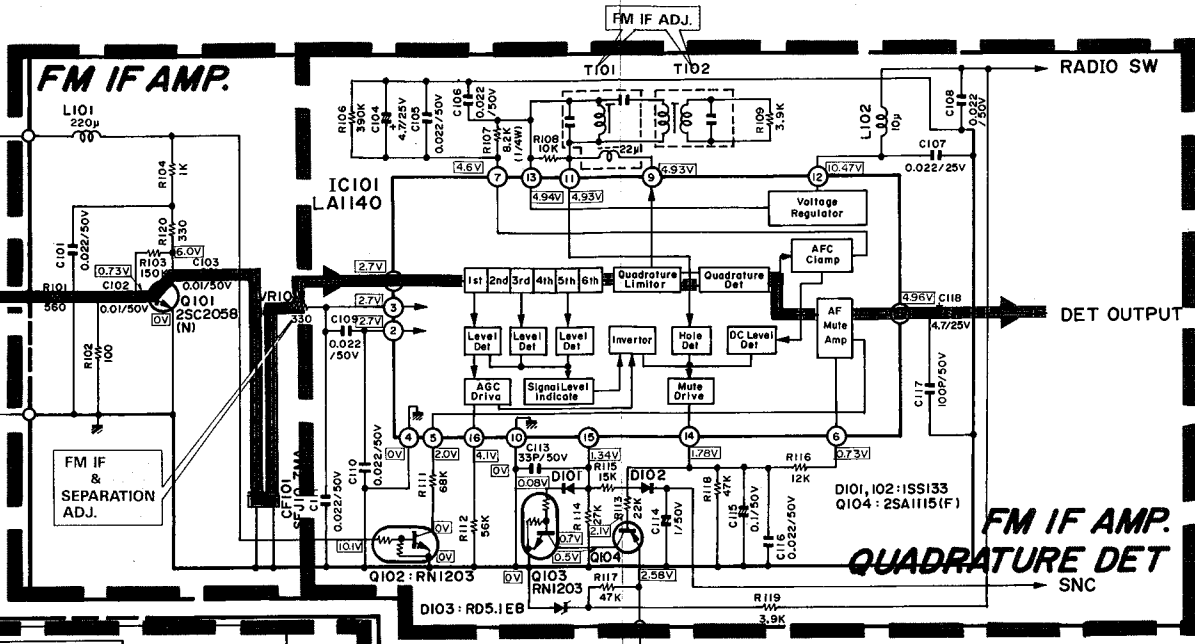

A

SCHEMATIC DIAGRAM (2)

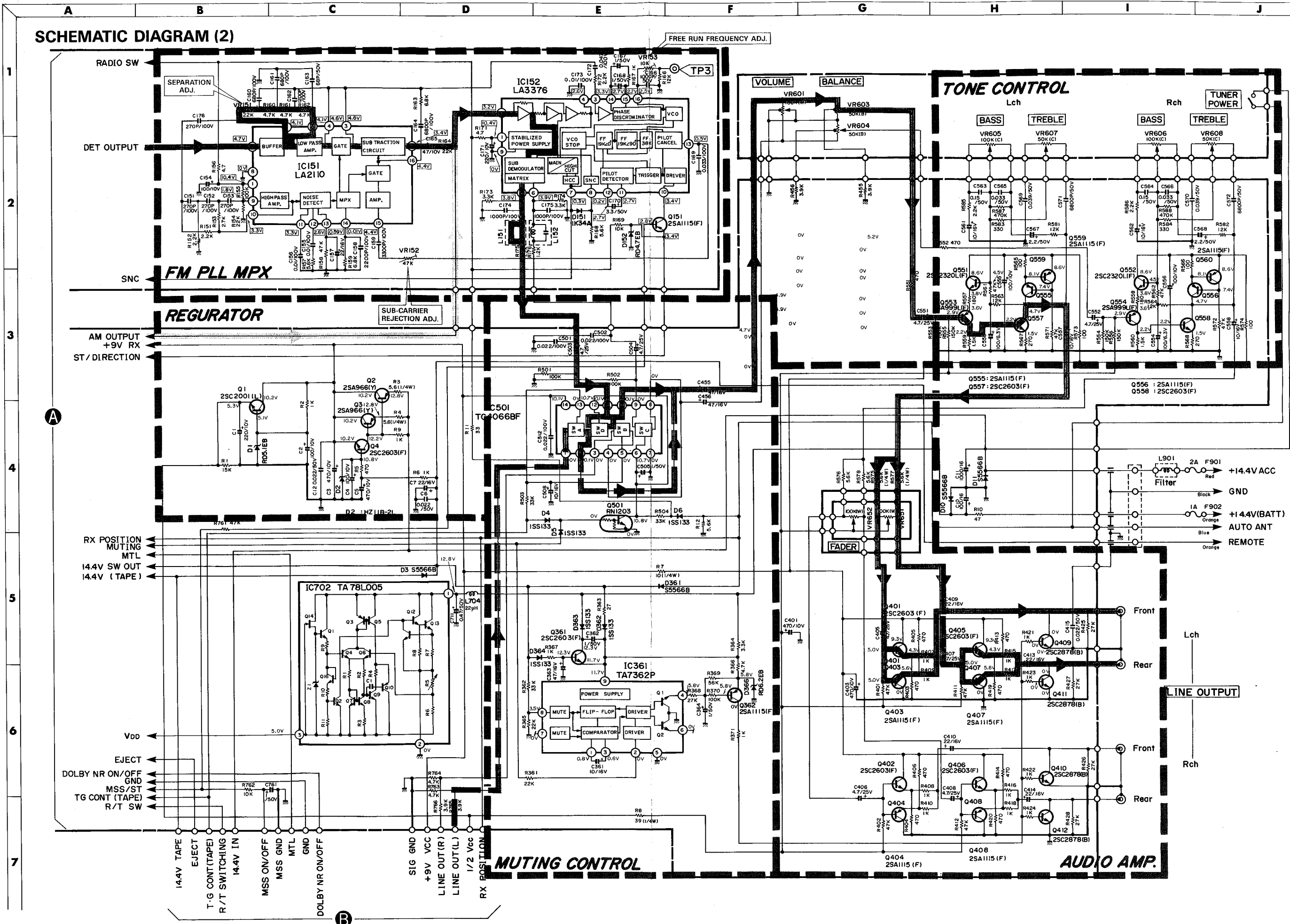

SCHEMATIC DIAGRAM (2)

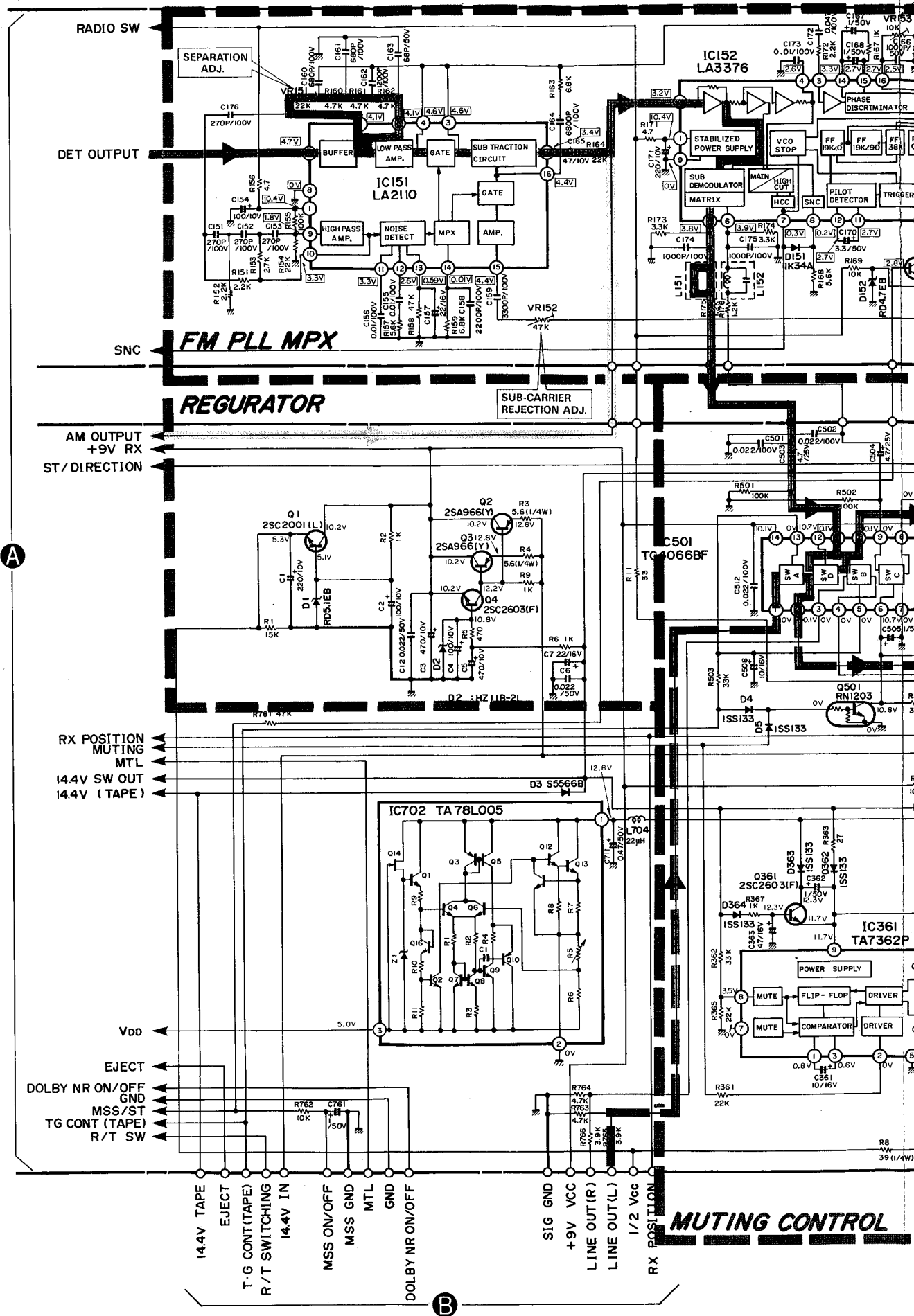

F

G

H

I

J

FREE RUN FREQUENCY ADJ.

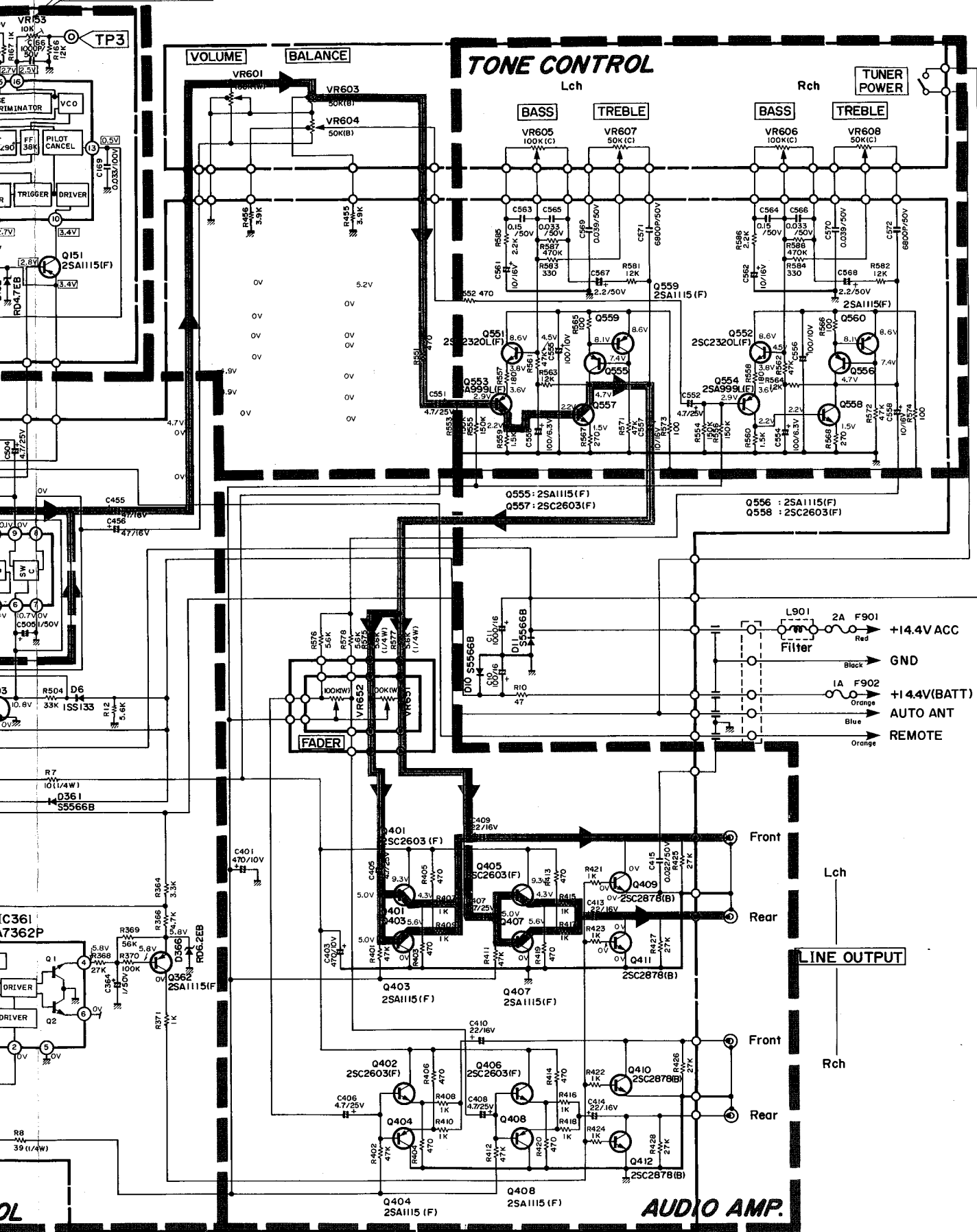

TONE CONTROL

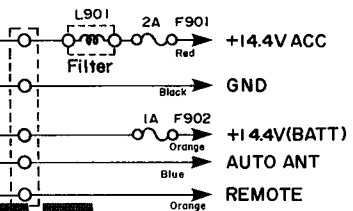
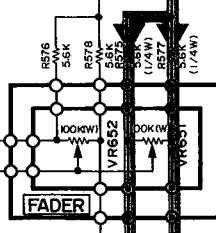
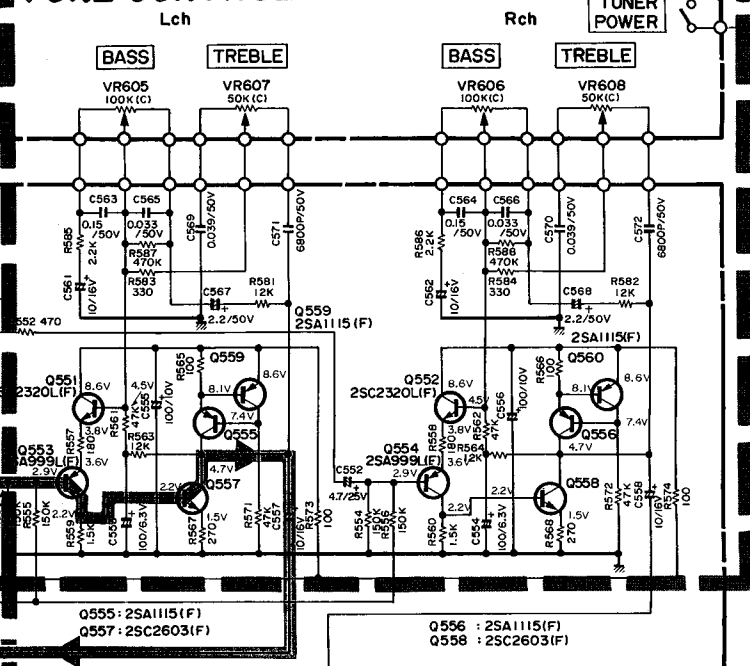

AUDIO AMP.

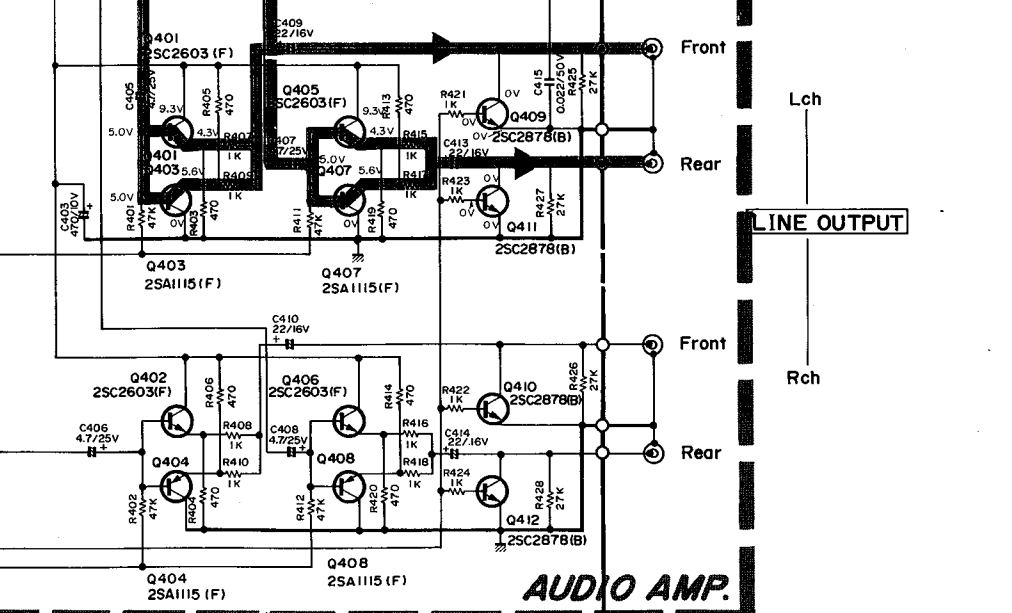

DL

SCHEMATIC DIAGRAM (3)

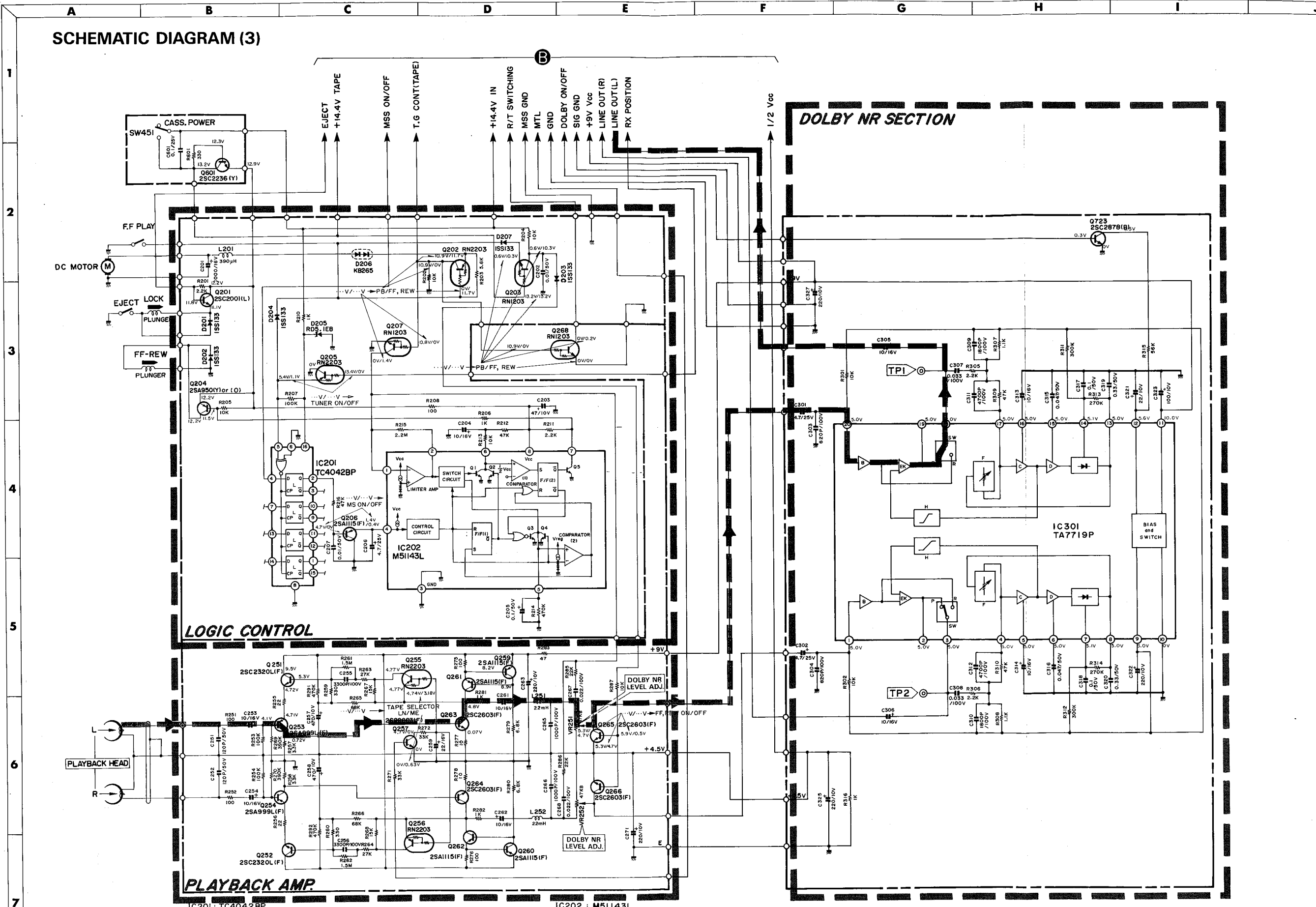

IC201: TC4042BP

Pin No.	1	2	3	4	5	6	7	8	9	10	11	12	13	14	15	16
PB	4.8V	0V	4.0V	0.2V	0.4V	0V	0V	0V	0V	4.8V	4.8V	0V	0V	0V	4.8V	4.8V
TUNER OFF FF, REW MS OFF	4.8V	0V	4.8V	0.2V	1.2V	0V	0V	0V	0V	4.8V	4.8V	0V	0V	0V	4.8V	4.8V
TUNER OFF FF, REW MS ON	4.8V	4.8V	0V	5.0V	1.2V	0V	0V	0V	0V	4.8V	4.8V	0V	0V	0V	4.8V	4.8V
TUNER ON FF, REW MS ON	4.8V	4.8V	0V	0.4V	5.4V	0V	0V	0V	0V	4.8V	4.8V	0V	0V	0V	4.8V	4.8V

IC202: M51143L

Pin No.	1	2	3	4	5	6	7	8
PB	0V	2.7V	0V	0.5V	0V	0V	0.2V	11.1V
FF, REW MS OFF	1.4V	1.4V	0V	0.5V	0V	0V	0.2V	11.1V
FF, REW MS ON	1.4V	1.4V	0V	1.4V	0V	1.7V	0.2V	11.2V

- FM SIGNAL
 - AM SIGNAL
 - PLAYBACK SIGNAL
1. ALL RESISTANCES VALUES ARE IN Ω.
 - KΩ = 1000Ω, MΩ = 1000KΩ.
 2. THE WATTAGE OF RESISTORS IS 1/8W UNLESS OTHERWISE NOTED.
 3. ALL CAPACITANCES VALUES ARE IN μF UNLESS OTHERWISE NOTED. P = μF
 4. V: DC VOLTAGE AT NO SIGNAL
 - [V] FM POSITION
 - [...V] AM POSITION

SCHEMATIC DIAGRAM (3)

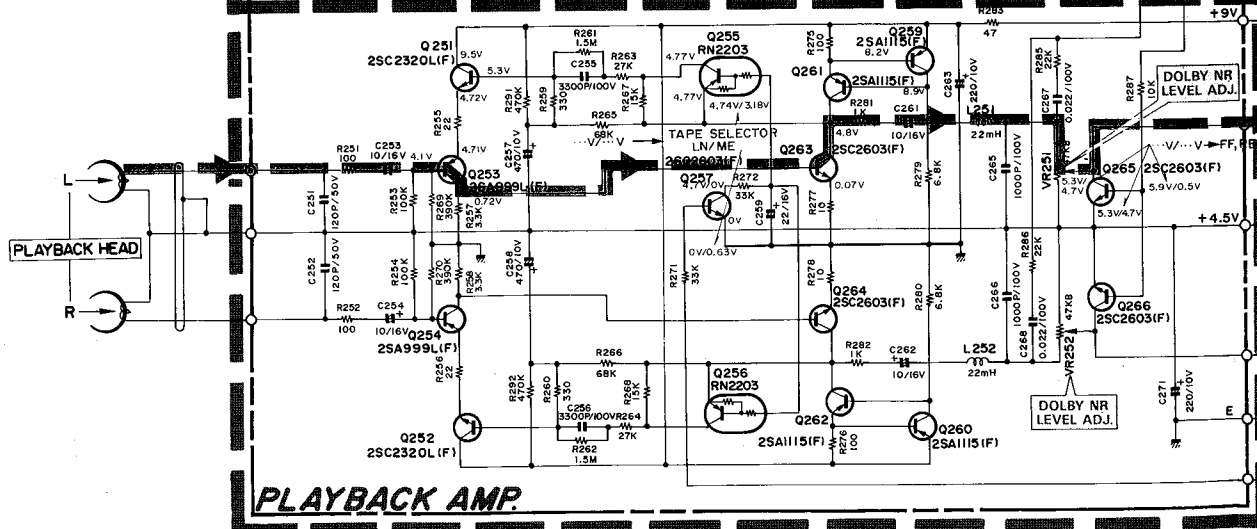
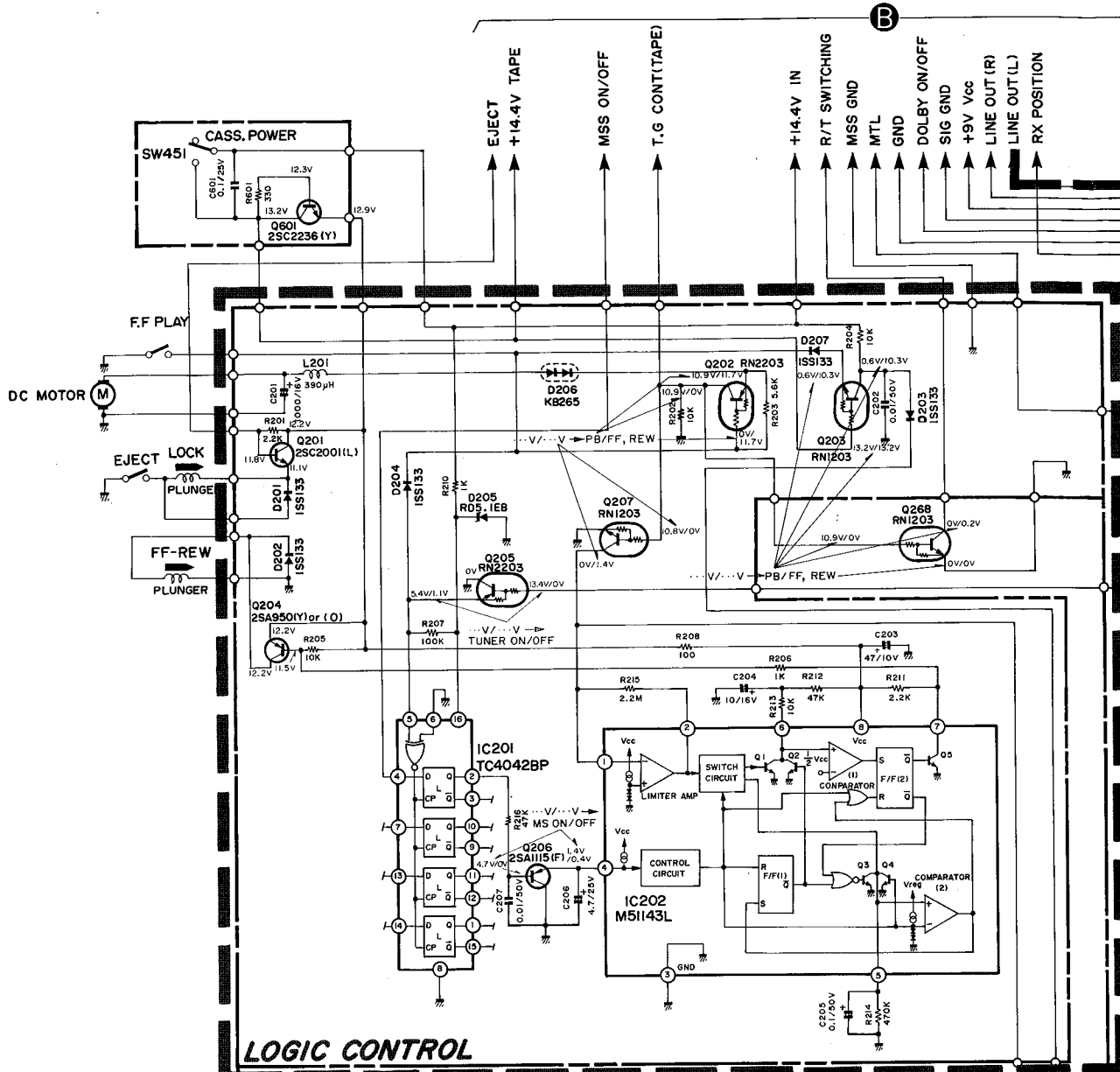

IC201 : TC4042BP

	PIN NO.	1	2	3	4	5	6	7	8	9	10	11	12	13	14	15	16
PB		4.8V	0V	4.8V	0.2V	0.4V	0V	0V	0V	0V	4.8V	4.8V	0V	0V	0V	4.8V	4.8V
TUNER OFF FF, REW MS OFF		4.8V	0V	4.8V	0.2V	1.2V	0V	0V	0V	0V	4.8V	4.8V	0V	0V	0V	4.8V	4.8V
TUNER OFF FF, REW MS ON		4.8V	4.8V	0V	5.0V	1.2V	0V	0V	0V	0V	4.8V	4.8V	0V	0V	0V	4.8V	4.8V
TUNER ON FF, REW MS ON		4.8V	4.8V	0V	0.4V	5.4V	0V	0V	0V	0V	4.8V	4.8V	0V	0V	0V	4.8V	4.8V

IC202 : M51143L

	PIN NO.	1	2	3	4
PB		0V	2.7V	0V	0.5V
FF, REW MS OFF		1.4V	1.4V	0V	0.5V
FF, REW MS ON		1.4V	1.4V	0V	1.4V

F G H I J

1/2 Vcc

DOLBY NR SECTION

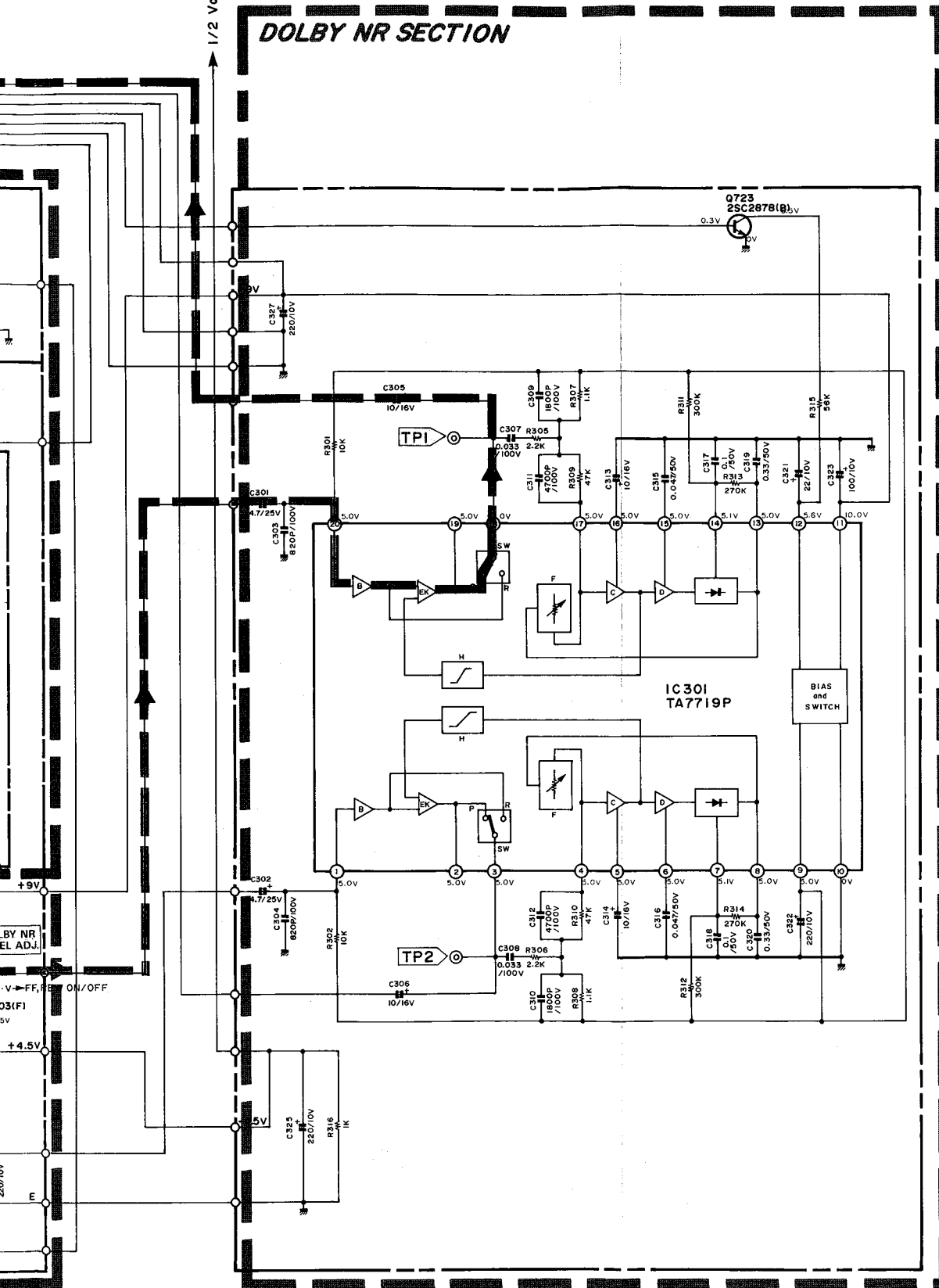

BY NR
EL. ADJ.

FF, P ON/OFF

03(F)
5V

3	4	5	6	7	8
0V	0.5V	0V	0V	0.2V	11.1V
0V	0.5V	0V	0V	0.2V	11.1V
0V	1.4V	0V	1.7V	0.2V	11.2V

..... FM SIGNAL
 - - - - - AM SIGNAL
 - - - - - PLAYBACK SIGNAL

1. ALL RESISTANCES VALUES ARE IN Ω.
KΩ = 1000Ω, MΩ = 1000KΩ.
2. THE WATTAGE OF RESISTORS IS 1/8W UNLESS OTHERWISE NOTED.
3. ALL CAPACITANCES VALUES ARE IN pF UNLESS OTHERWISE NOTED. P = μF
4. V: DC VOLTAGE AT NO SIGNAL
 [---] FM POSITION
 (...) AM POSITION

WIRING DIAGRAM

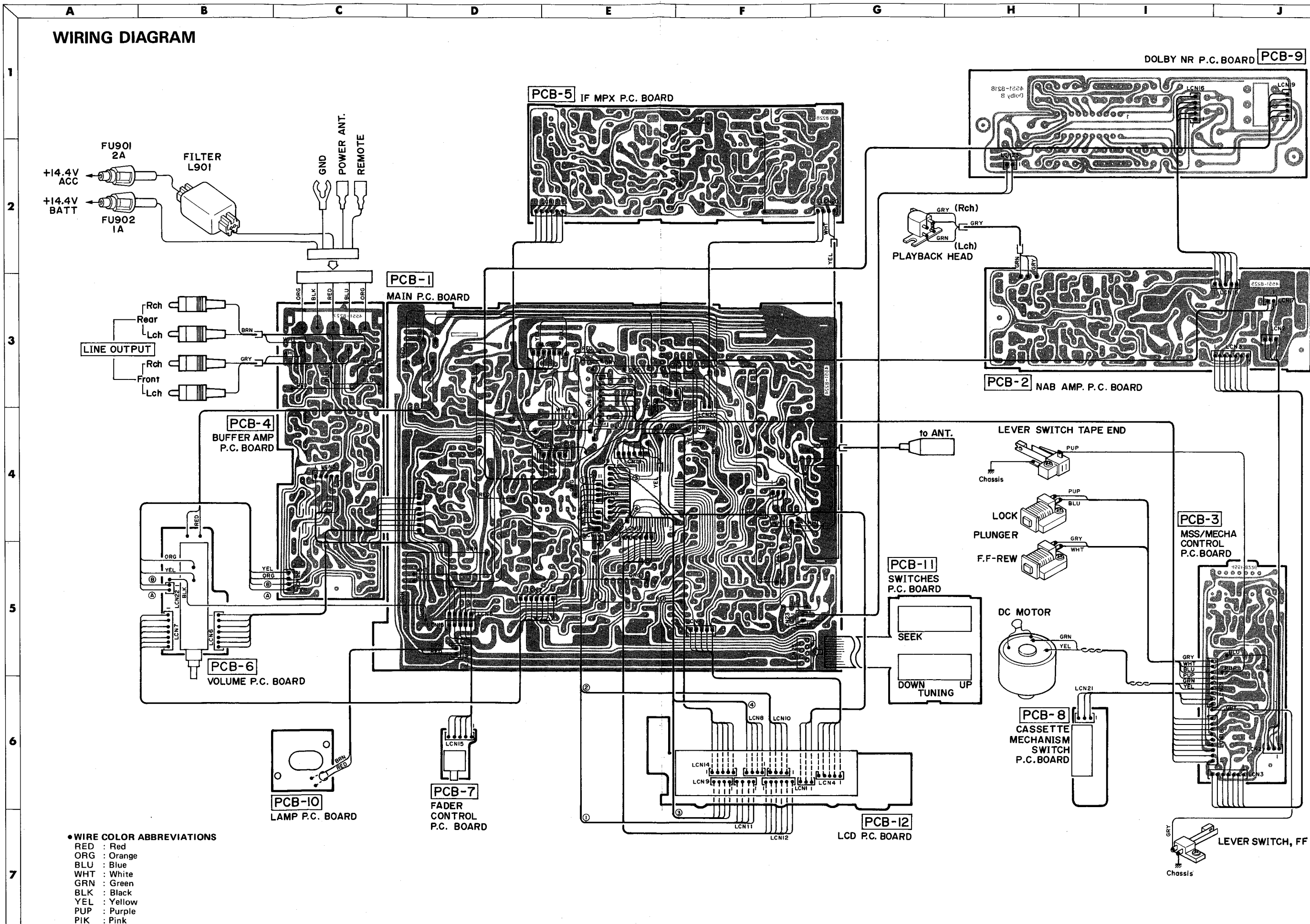

- WIRE COLOR ABBREVIATIONS
- RED : Red
 - ORG : Orange
 - BLU : Blue
 - WHT : White
 - GRN : Green
 - BLK : Black
 - YEL : Yellow
 - PUP : Purple
 - PIK : Pink

WIRING DIAGRAM

1
2
3
4
5
6
7

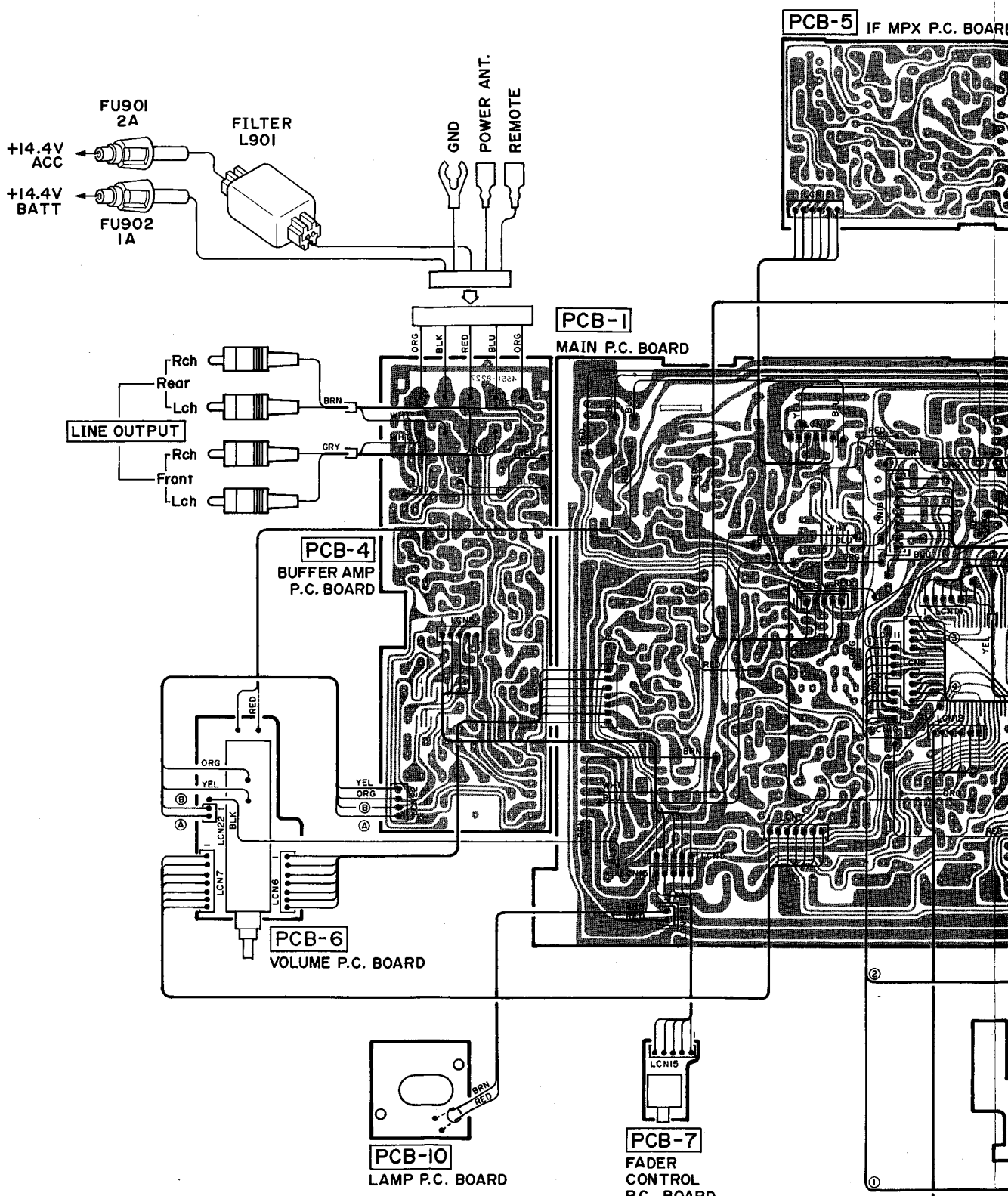

- WIRE COLOR ABBREVIATIONS
- RED : Red
 - ORG : Orange
 - BLU : Blue
 - WHT : White
 - GRN : Green
 - BLK : Black
 - YEL : Yellow
 - PUP : Purple
 - PIK : Pink

F

G

H

I

J

DOLBY NR P.C. BOARD PCB-9

BOARD

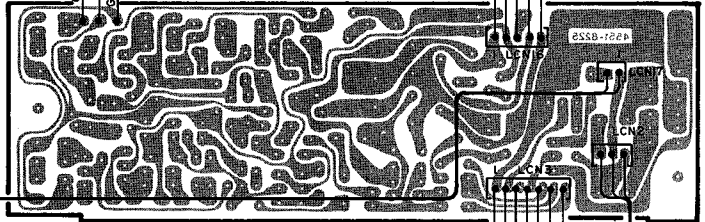
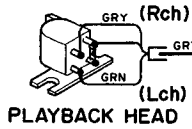
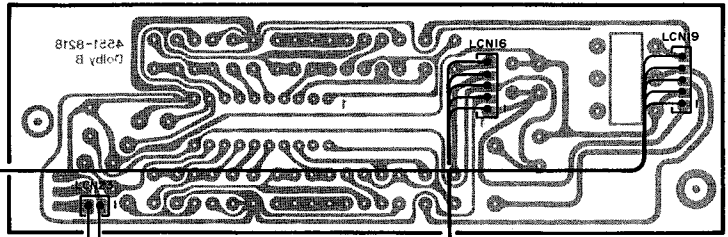
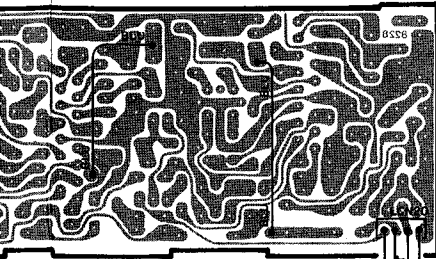

PCB-2 NAB AMP. P.C. BOARD

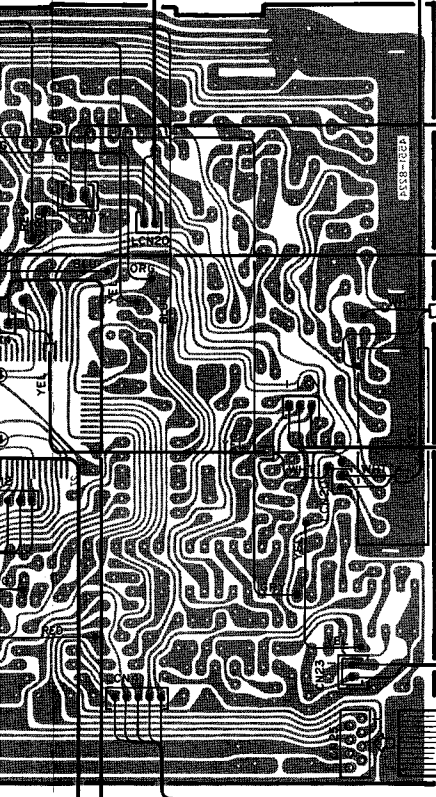

PCB-11 SWITCHES P.C. BOARD

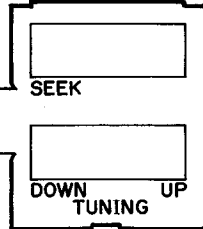

to ANT.

LEVER SWITCH TAPE END

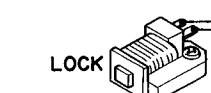
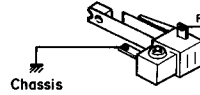

DC MOTOR

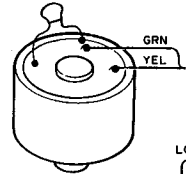

PCB-8 CASSETTE MECHANISM SWITCH P.C. BOARD

PCB-3 MSS/MECHA CONTROL P.C. BOARD

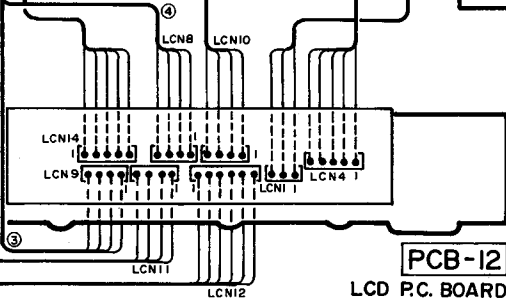
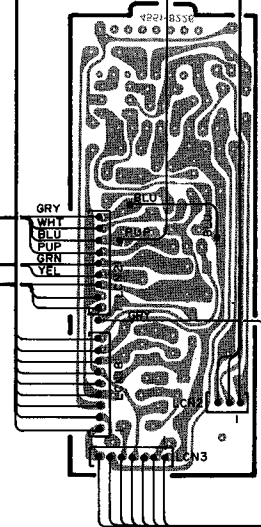

PCB-12 LCD P.C. BOARD

P.C. BOARDS (1)

SW709	SW708	SW707	SW706	SW705	SW704	SW703	SW701
FM · AM	6	5	4	3	2	1	ME

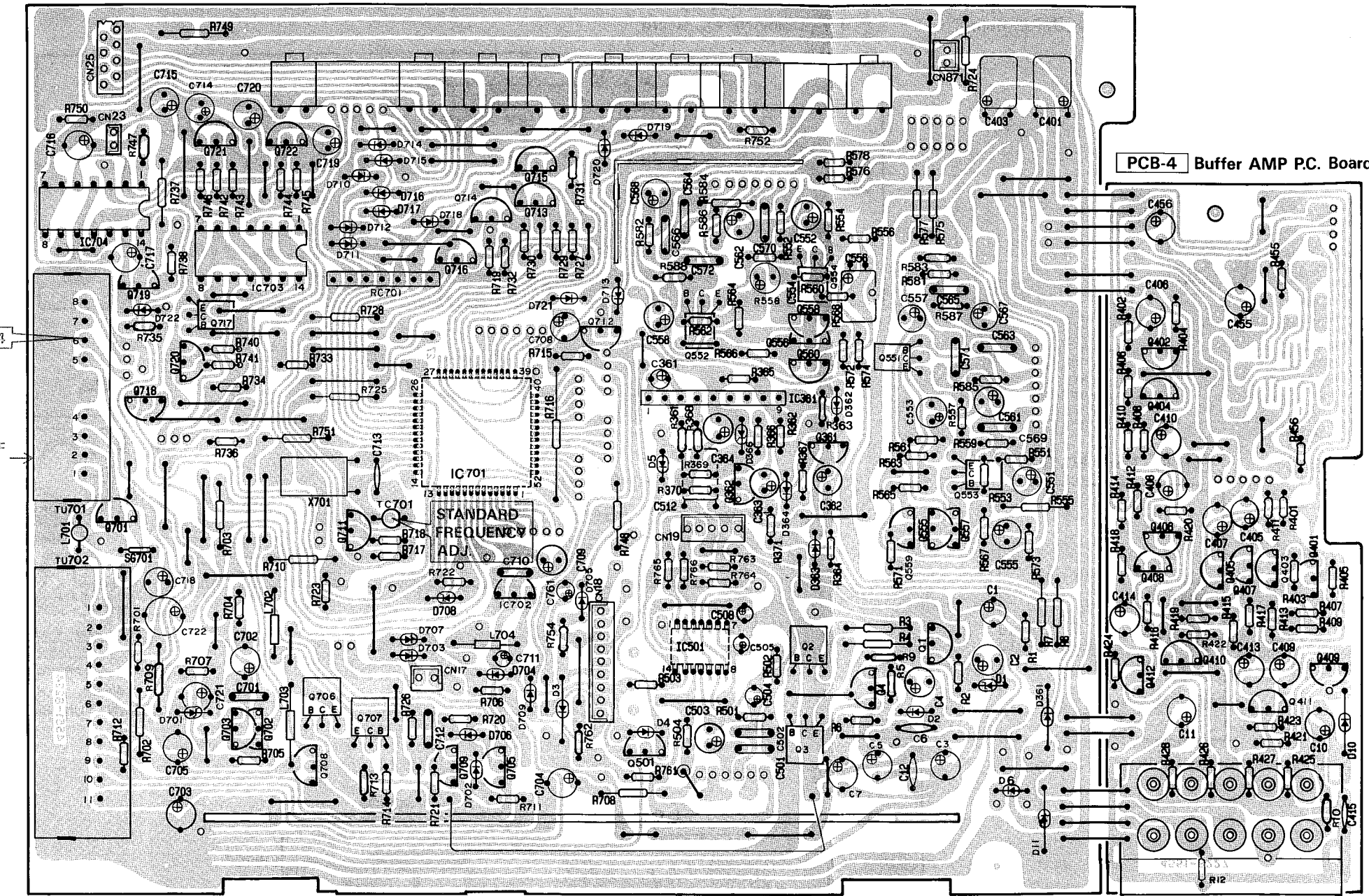

TP4
FM IF
ADJ.

PCB-4 Buffer AMP P.C. Board

PCB-2 NAB AMP P.C. Board

DOLBY NR
LEVEL ADJ.

PCB-3 MSS/Mecha Control P.C. Board

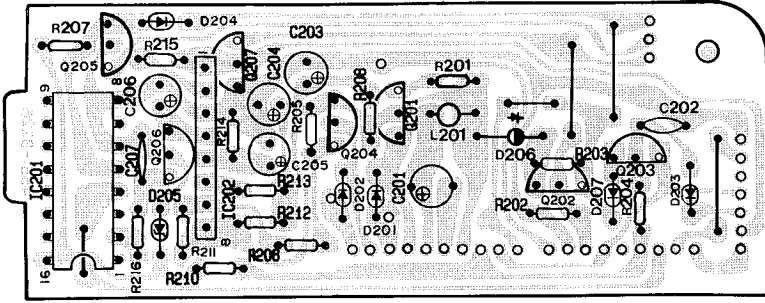

PCB-5 IF MPX P.C. Board

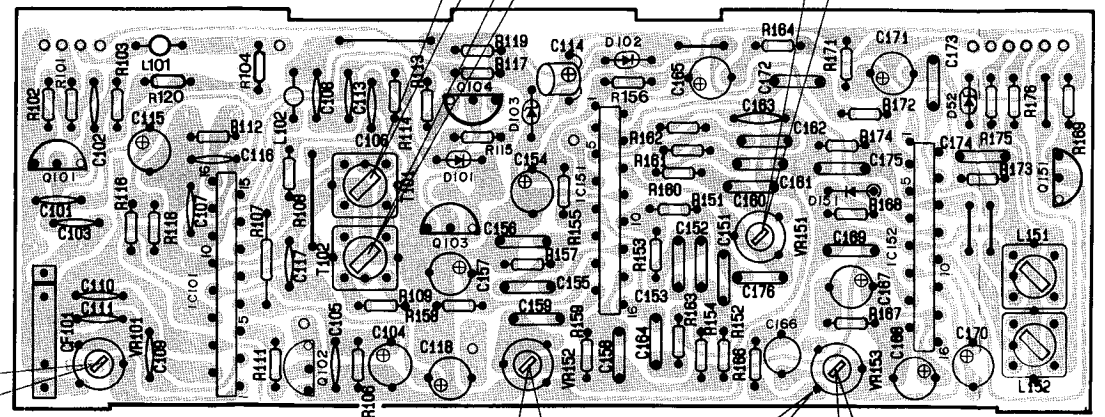

P.C. BOARDS (1)

PCB-1 Main P.C. Board

SW709
FM·AM

SW708 SW707 SW706 SW705 SW704 SW703

SW

1
2
3
4
5
6
7

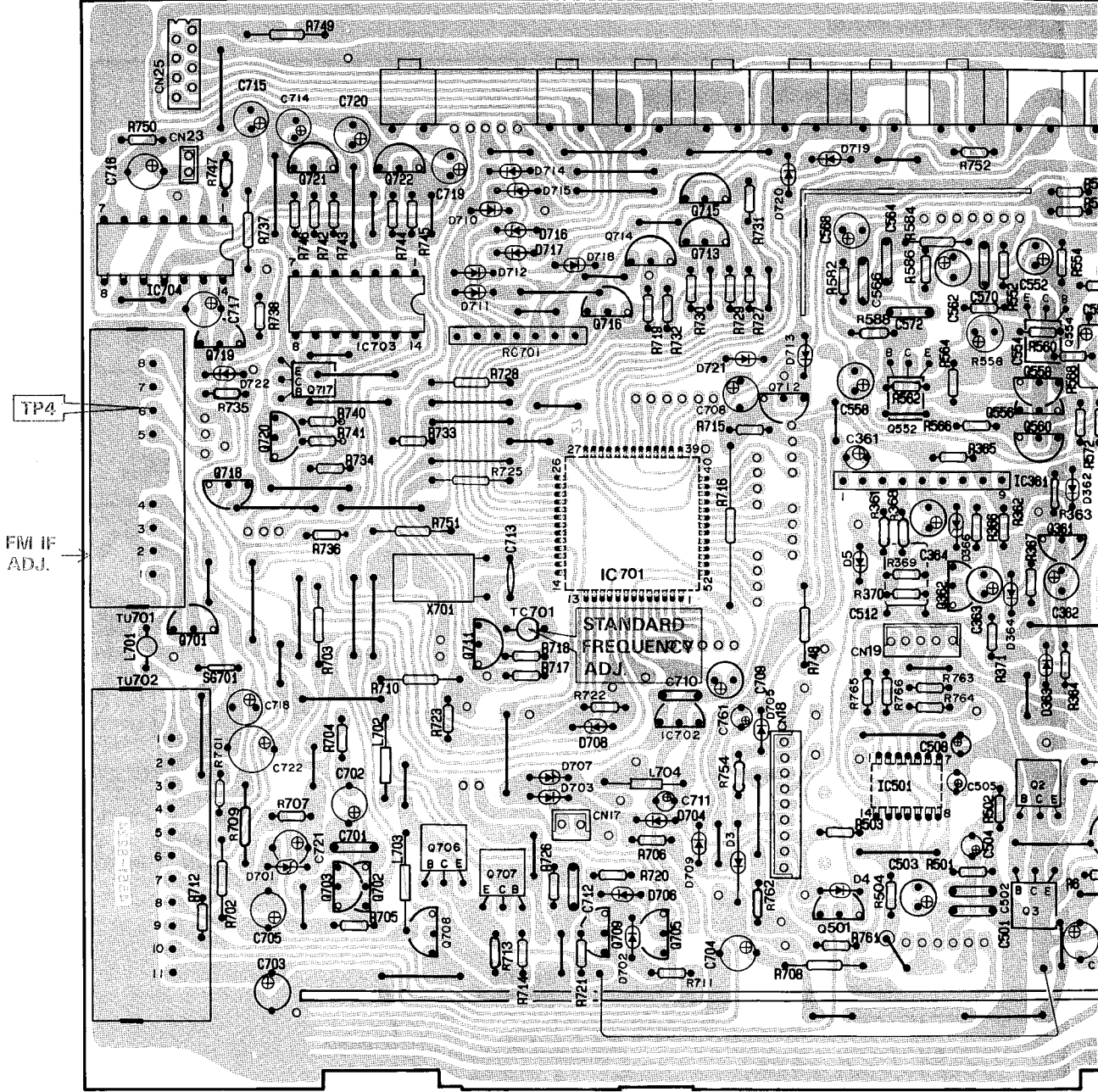

TP4
FM IF
ADJ.

STANDARD
FREQUENCY
ADJ.

PCB-3 MSS/Mecha Control P.C. Board

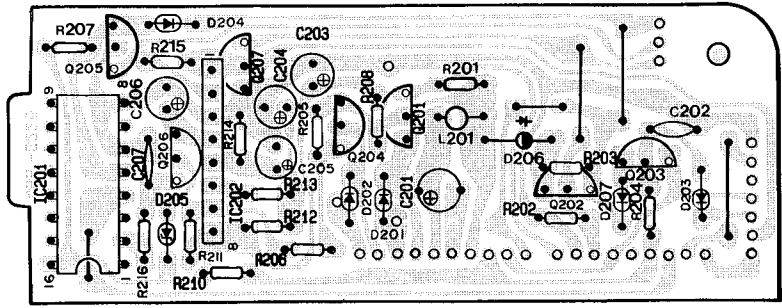

PCB-5 IF MPX PC.

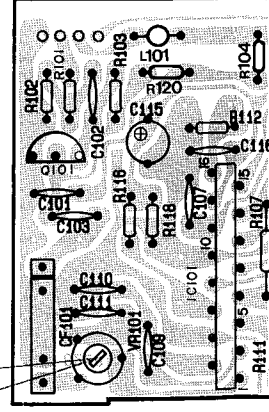

FM IF
&
SEPARATION
ADJ.

F

G

H

I

J

SW701
ME

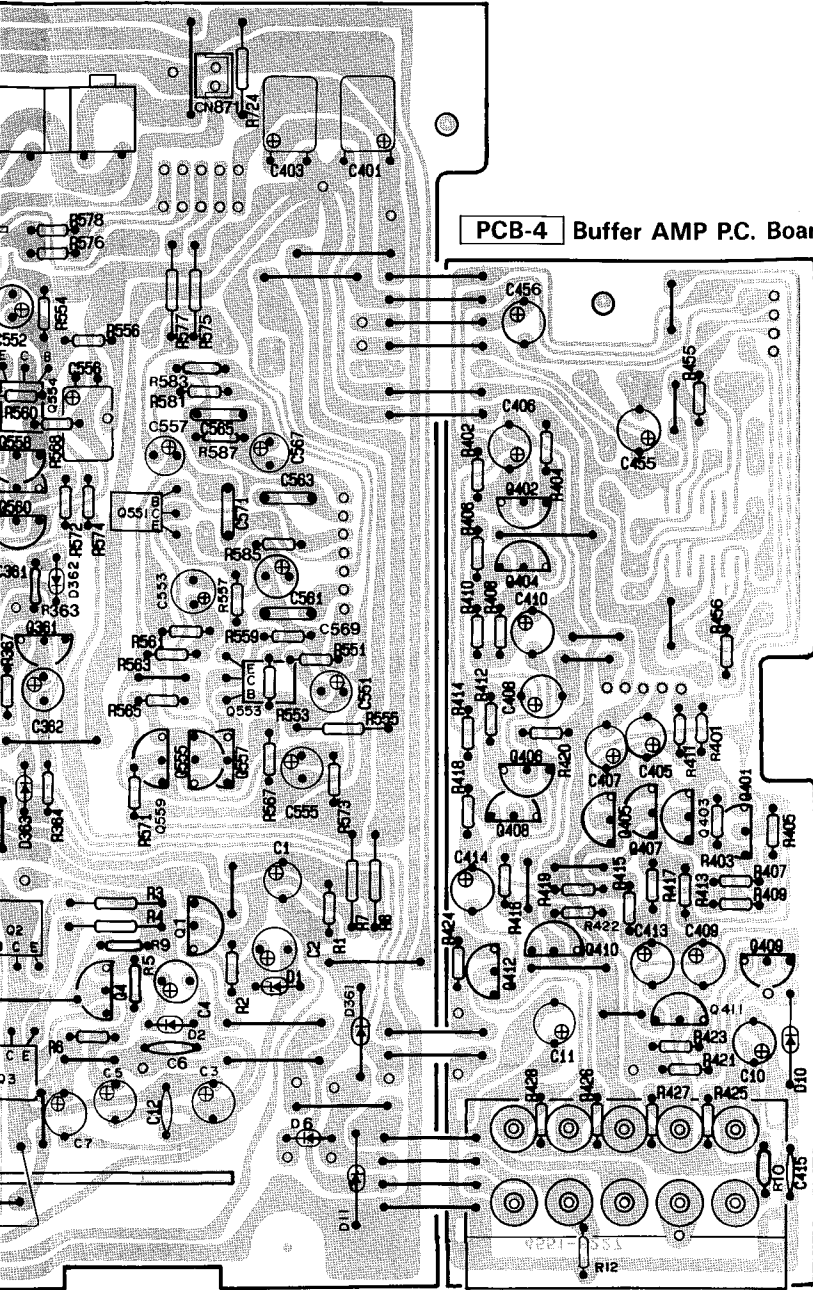

PCB-2 NAB AMP PC. Board

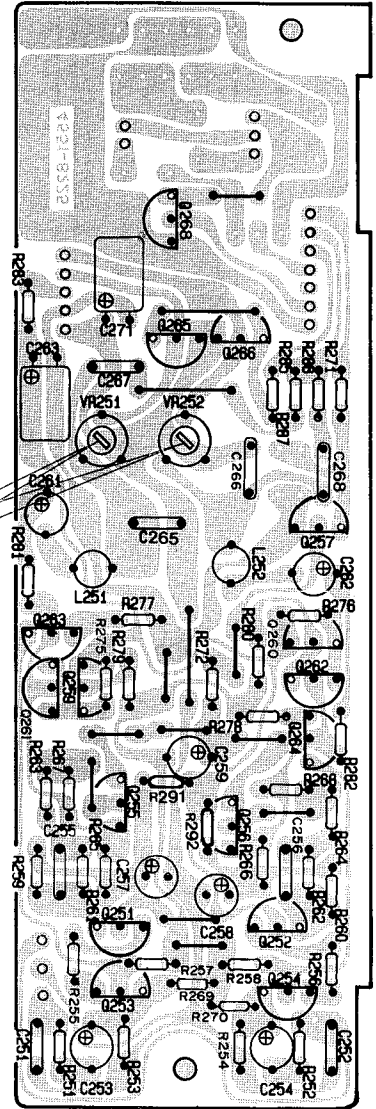

XPX PC. Board

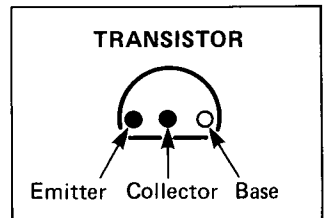
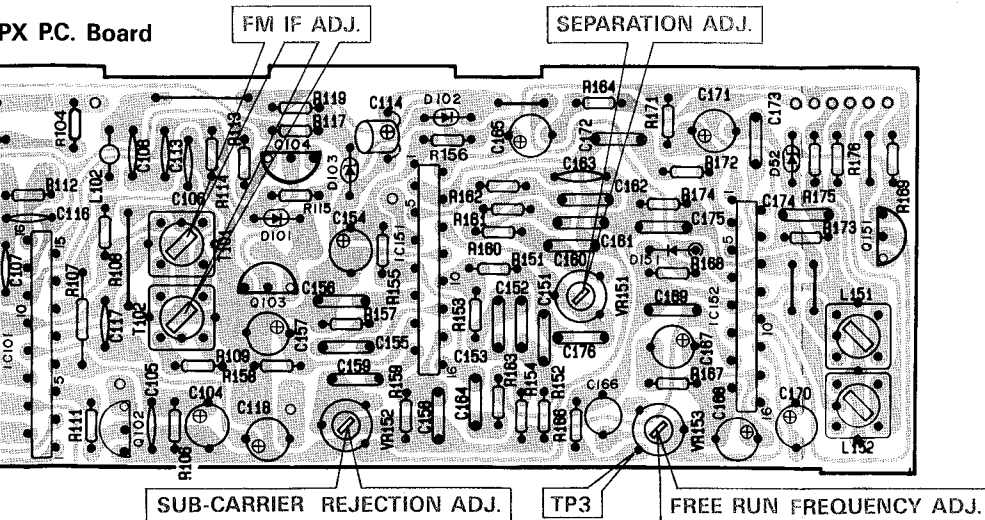

PC. BOARDS (2)

PCB-6 Volume P.C. Board

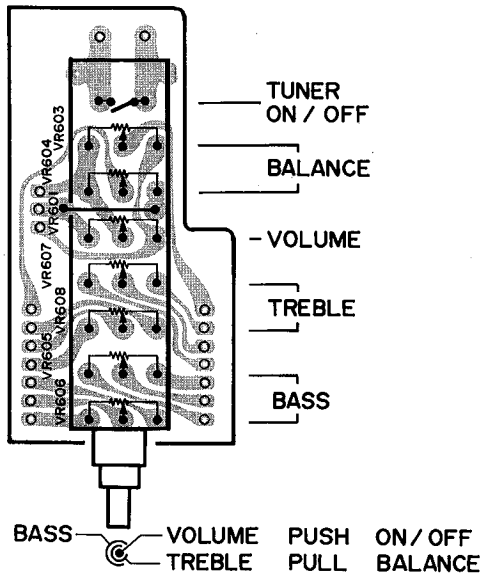

PCB-8 Cassette Mechanism Switch P.C. Board

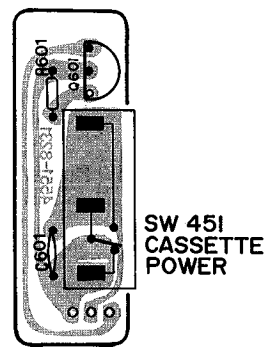

PCB-9 Dolby NR P.C. Board

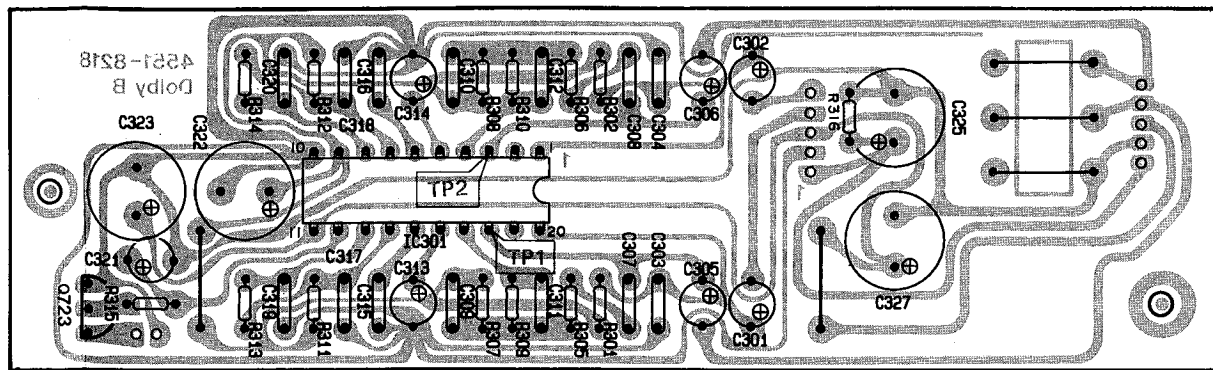

PCB-7 Fader Control P.C. Board

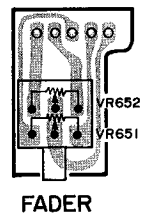

PCB-10 Lamp P.C. Board

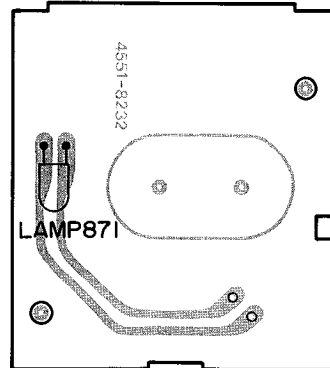

PCB-11 Switches P.C. Board

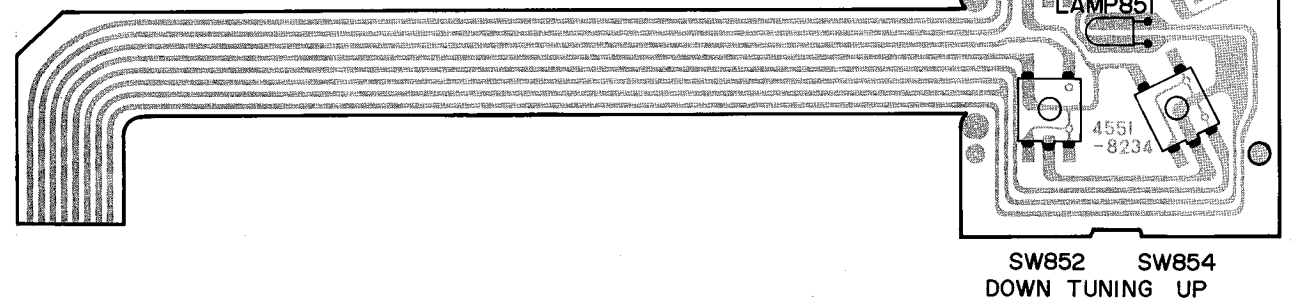

PCB-12 LCD P.C. Board

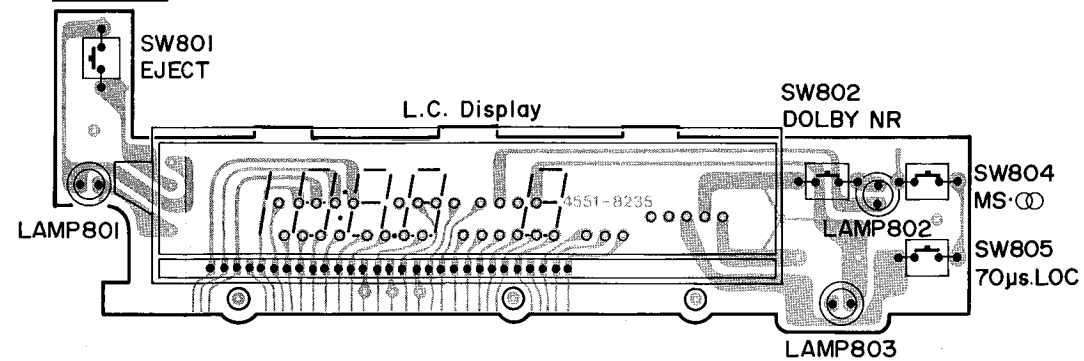

PIN CONNECTION DIAGRAM OF TRANSISTORS, DIODES AND ICs.

<p>2SC2001 2SA966 2SC2320L 2SA999L 2SC3246 2SA950 2SC2878</p>	<p>2SC2058 2SC2236</p>	<p>2SC2603 2SA1115 RN1203 RN2203</p>	<p>TA78L005</p>	<p>TA7362P</p>	<p>TC4013BP</p>	<p>LA3376</p>	<p>TC4042BP</p>	<p>µPD1708G-011</p>
<p>RD5.1EB HZ11B-2L S5566B 1SS133 RD6.2EB RD10EB 1K34A RD4.7EB</p>	<p>KB265</p>	<p>M51143L</p>	<p>TC4011BP</p>	<p>LA2110</p>	<p>LA1140</p>	<p>TA7719P</p>		

P.C. BOARDS (2)

PCB-6 Volume P.C. Board

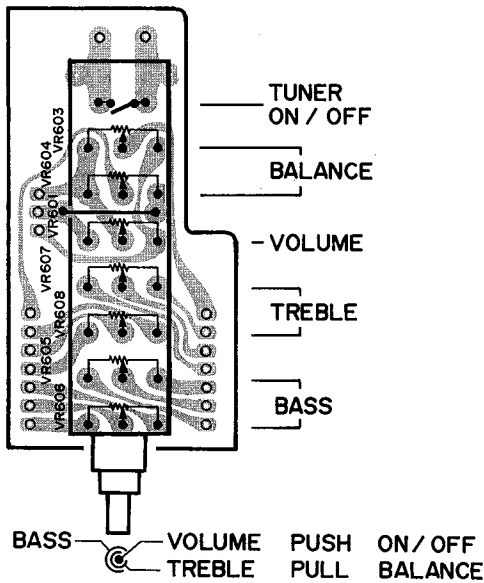

PCB-8 Cassette Mechanism Switch P.C. Board

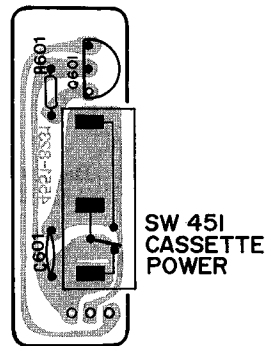

PCB-9



PCB-7 Fader Control P.C. Board

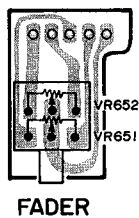

PCB-10 Lamp P.C. Board

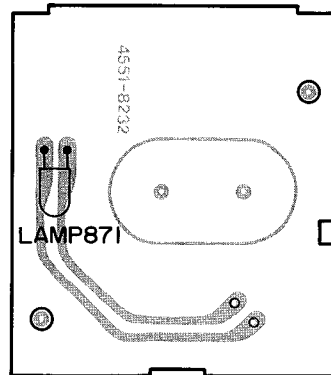

PCB-12 LCD

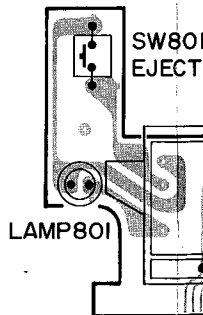

PIN CONNECTION DIAGRAM OF TRANSISTORS, DIODES AND ICs.

2SC2001 2SA966 2SC2320L 2SA999L 2SC3246 2SA950 2SC2878 	2SC2058 2SC2236 	2SC2603 2SA1115 RN1203 RN2203 	TA78L005 	TA7362P 	TC4013BP 	LA3376 	TC40...
RD5.1EB HZ11B-2L S5666B 1SS133 RD6.2EB RD10EB 1K34A RD4.7EB 	KB265 	M51143L 	TC4011BP 	LA2110 	LA1140 	TA77... 	

CB-9 Dolby NR P.C. Board

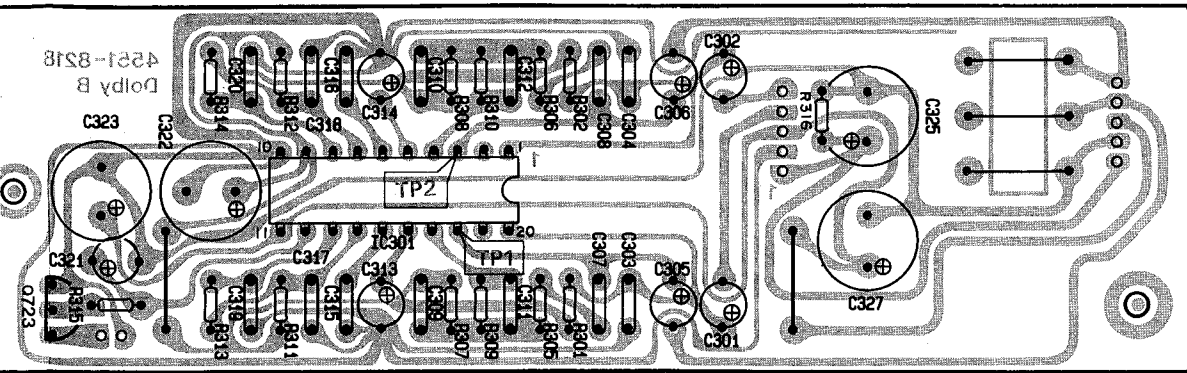

PCB-11 Switches P.C. Board

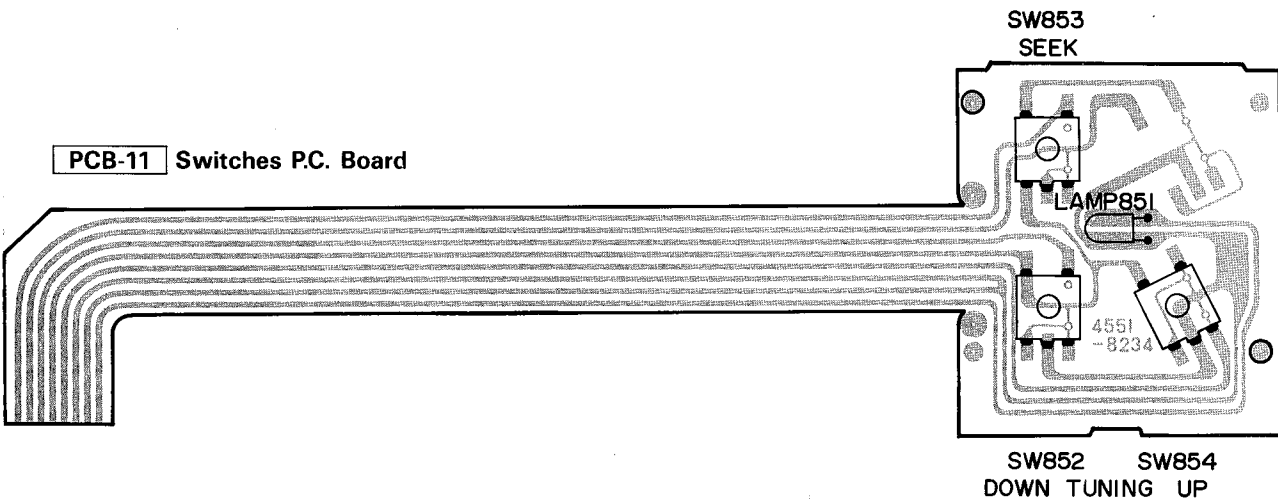

2 LCD P.C. Board

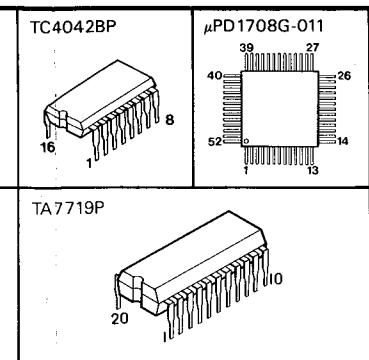
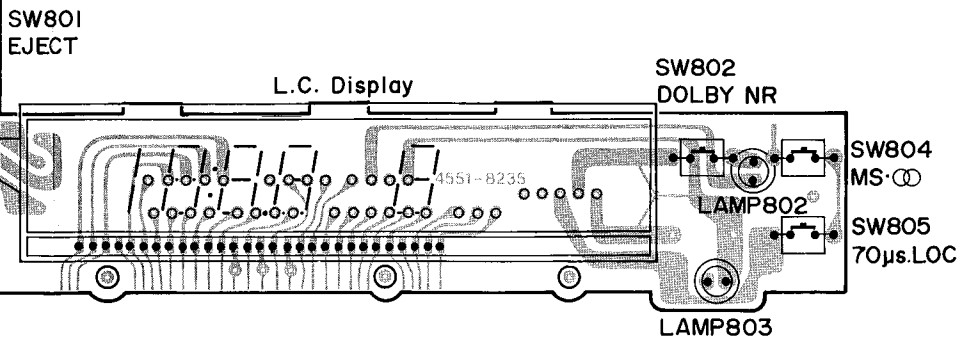

GENERAL UNIT EXPLODED VIEW

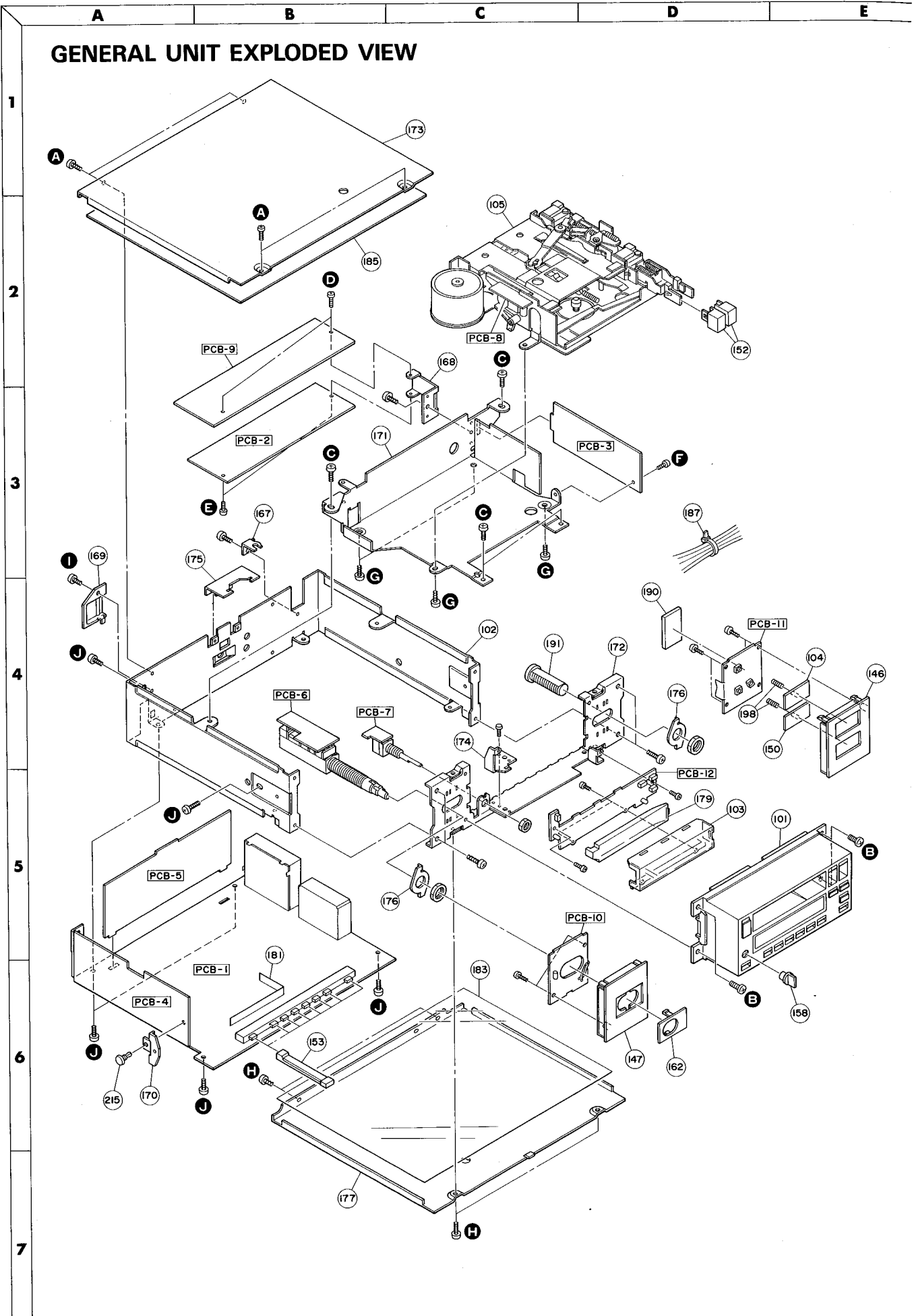

GENERAL UNIT PARTS LIST

Ref. No.	Part No.	Description
101	A442-CH140C	Center Panel Assembly
102	B211-CH140A	Chassis Assembly
103	B240-CH140A	Holder Assembly
104	A662-CH140A	Push Button Assembly, Seek
105	C112-CH140A	Cassette Tape Player Mechanical Assembly
146	1442-10102	Right Side Panel
147	1442-10201	Left Side Panel
150	1662-17401	Push Button, Tuning Up, Tuning Down
152	1662-17601	Push Button, F.F., Rew.
153	1662-17701	Push Button, Memory, Preset
158	1632-14101	Knob, Fader
162	1742-04001	Ornament
167	2219-1859	Bracket
168	2219-1861	Bracket
169	2219-1862	Bracket
170	2219-1863	Bracket
171	2219-1864	Bracket
172	2219-1865	Bracket
173	2219-1866	Bracket
174	2219-1868	Bracket
175	2219-8054	Bracket
176	2219-8029	Bracket
177	2219-1866	Bracket
179	2223-39	Reflector
181	2216-7158	Shield Plate
183	2224-7103	Insulator
185	2224-7107	Insulator
187	2240-7120	Holder
190	2224-01412	Insulator
191	2360-4	Shaft
198	2651-2101722	Spring
215	2459-3005511	Snap-in-fastener

CASSETTE MECHANISM EXPLODED VIEW

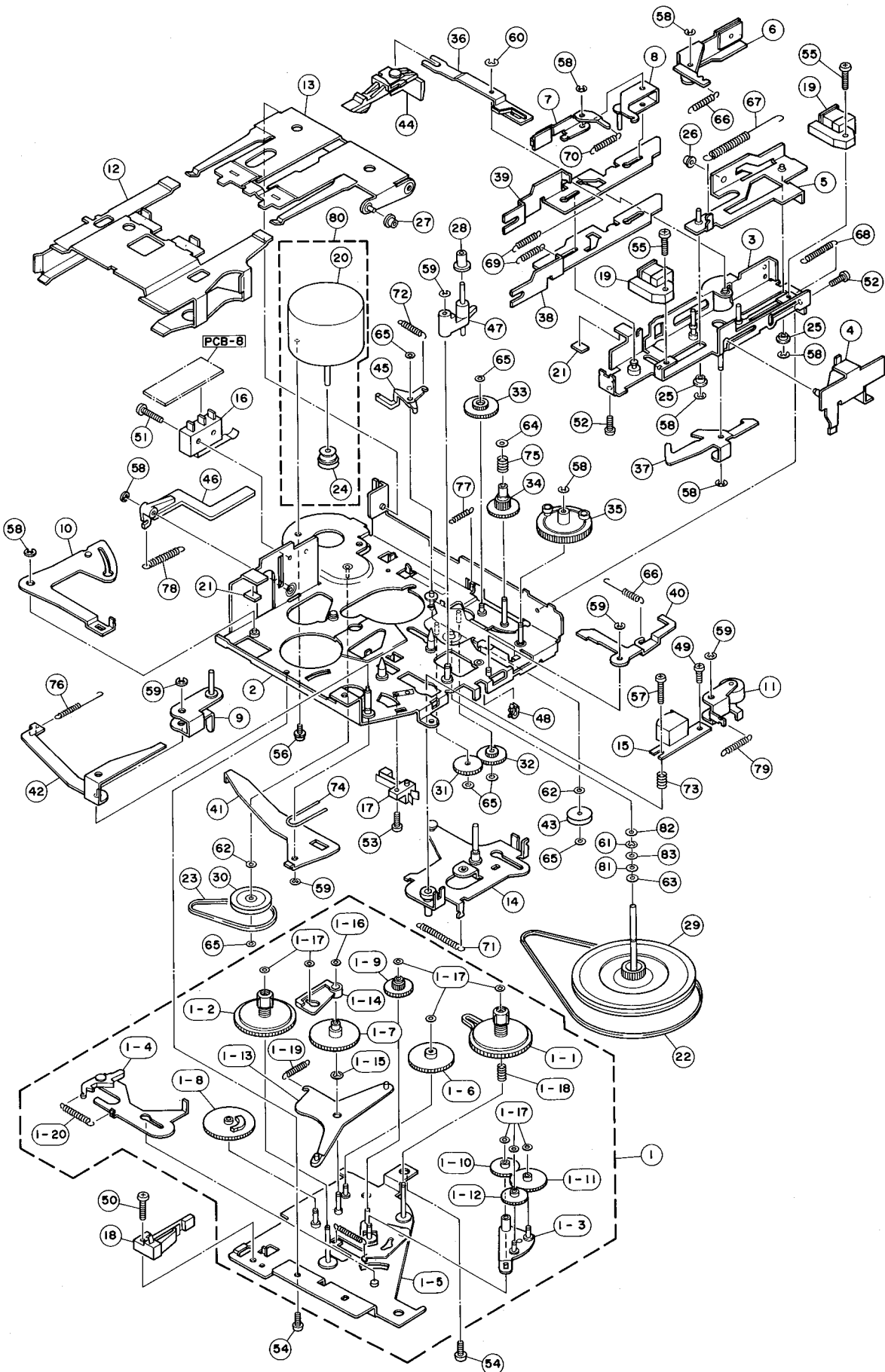

CASSETTE MECHANISM PARTS LIST

Ref. No.	Part No.	Description
1	960-3420-03	Bottom Sub Assembly
1-1	960-3421-01	Reel Base Assembly
1-2	960-3422-01	Reel Base Assembly
1-3	960-3433-03	FF Gear Plate Assembly
1-4	960-3434-01	SW Plate Assembly
1-5	960-3455-03	Bottom Plate Assembly
1-6	613-0022-01	Gear A
1-7	613-0022-00	Gear B
1-8	613-0024-01	Cam Gear
1-9	613-0025-00	Idler Gear
1-10	613-0026-01	FF Base Gear
1-11	613-0027-00	FF Gear
1-12	613-0028-00	REW Gear
1-13	631-0396-01	Sensing Link
1-14	631-0397-01	Replay Sensing
1-15	744-0006-01	Special E-stop Ring
1-16	745-0647-00	Special Washer
1-17	746-0628-01	Special Washer
1-18	750-2155-00	Spring
1-19	750-2217-00	Spring
1-20	750-2218-00	Spring
1-21	750-2219-00	Spring
2	960-3423-03	Deck Plate Assembly
3	960-3424-06	Frame Assembly
4	960-3425-03	Loading Plate Assembly
5	960-3426-06	Eject Plate Assembly
6	960-3427-02	Plunger Plate A Assembly
7	960-3428-00	Plunger Plate B Assembly
8	960-3429-02	Lock Plate Assembly
9	960-3430-02	FF Link A Assembly
10	960-3431-01	Replay Lever A Assembly
11	960-3437-00	Pinch Roller Assembly
12	606-0075-03	Cassette Pack Guide
13	960-3439-02	Guide Arm Assembly
14	960-3440-02	Head Plate Assembly
15	011-0293-00	Playback Head
16	013-2690-03	Lever Switch, Cassette Power (SW451)
17	013-3470-05	Lever Switch, FF
18	013-3558-02	Lever Switch, Tape End
19	015-0232-00	Plunger
20	020-0366-00	DC Motor
21	340-0398-00	Spacer
22	602-0074-00	Belt A
23	602-0075-00	Belt B
24	603-0083-07	Motor Pulley
25	610-0225-00	Guide Roller
26	610-0225-01	Guide Roller
27	610-0226-00	Guide Arm Roller
28	610-0227-01	Eject Roller
29	611-0065-01	Flywheel
30	613-0021-01	Pulley Gear
31	613-0029-00	Loading Gear A
32	613-0030-00	Loading Gear B
33	613-0031-00	Loading Gear C
34	613-0032-00	Loading Gear D
35	613-0033-00	Power Gear
36	630-1511-03	Loading Link
37	630-1513-01	Lock Link
38	630-1514-11	FF Lever
39	630-1515-11	REW Lever
40	630-1518-00	Lock Arm
41	630-1512-01	FF Link B
42	630-1526-00	Replay Link B
43	631-0370-00	Tension Pulley

A B C D E

CASSETTE MECHANISM EXPLODED VIEW

1
2
3
4
5
6
7

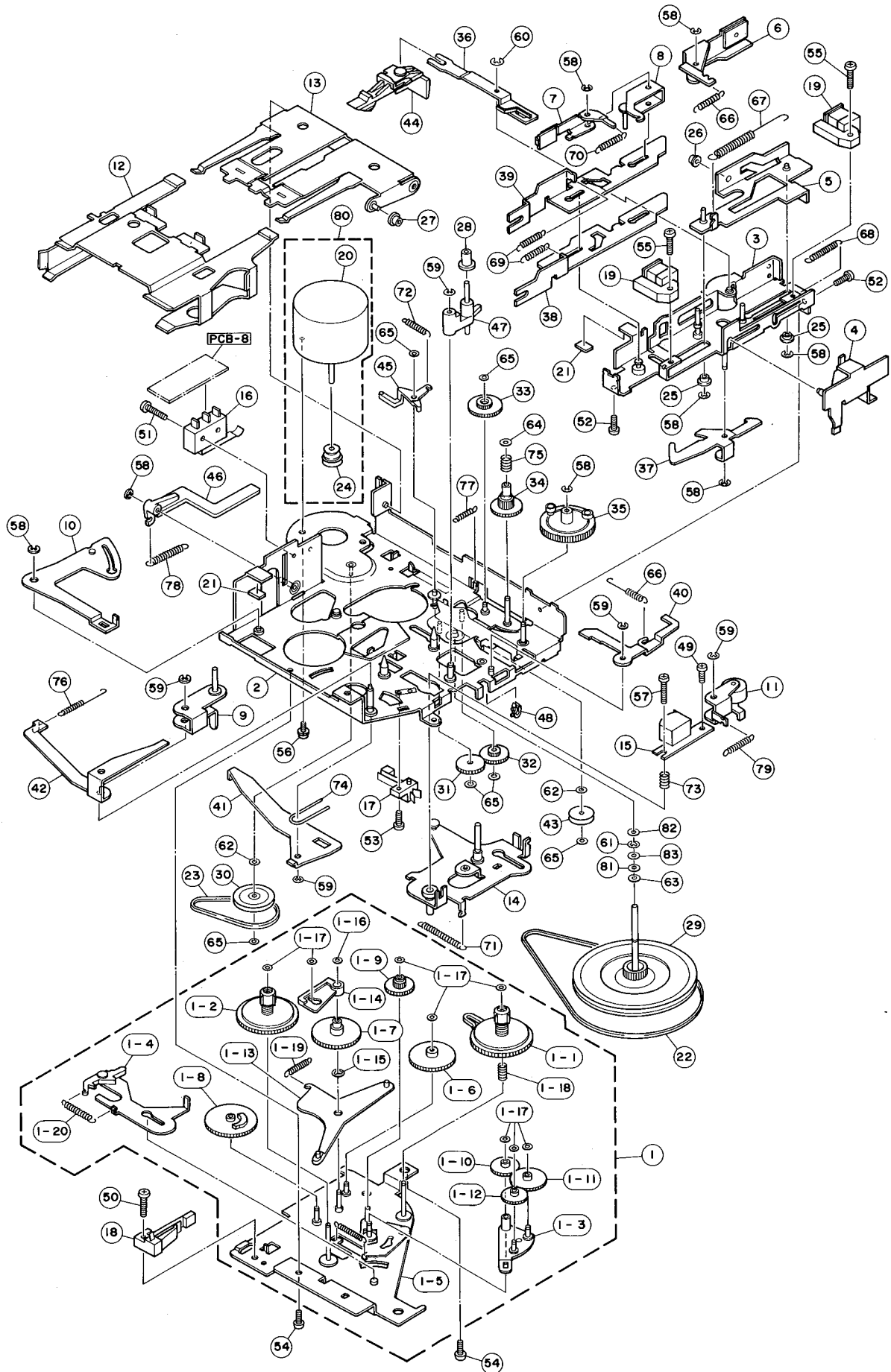

CASSETTE MECHANISM PARTS LIST

Ref. No.	Part No.	Description
1	960-3420-03	Bottom Sub Assembly
1-1	960-3421-01	Reel Base Assembly
1-2	960-3422-01	Reel Base Assembly
1-3	960-3433-03	FF Gear Plate Assembly
1-4	960-3434-01	SW Plate Assembly
1-5	960-3455-03	Bottom Plate Assembly
1-6	613-0022-01	Gear A
1-7	613-0022-00	Gear B
1-8	613-0024-01	Cam Gear
1-9	613-0025-00	Idler Gear
1-10	613-0026-01	FF Base Gear
1-11	613-0027-00	FF Gear
1-12	613-0028-00	REW Gear
1-13	631-0396-01	Sensing Link
1-14	631-0397-01	Replay Sensing
1-15	744-0006-01	Special E-stop Ring
1-16	745-0647-00	Special Washer
1-17	746-0628-01	Special Washer
1-18	750-2155-00	Spring
1-19	750-2217-00	Spring
1-20	750-2218-00	Spring
1-21	750-2219-00	Spring
2	960-3423-03	Deck Plate Assembly
3	960-3424-06	Frame Assembly
4	960-3425-03	Loading Plate Assembly
5	960-3426-06	Eject Plate Assembly
6	960-3427-02	Plunger Plate A Assembly
7	960-3428-00	Plunger Plate B Assembly
8	960-3429-02	Lock Plate Assembly
9	960-3430-02	FF Link A Assembly
10	960-3431-01	Replay Lever A Assembly
11	960-3437-00	Pinch Roller Assembly
12	606-0075-03	Cassette Pack Guide
13	960-3439-02	Guide Arm Assembly
14	960-3440-02	Head Plate Assembly
15	011-0293-00	Playback Head
16	013-2690-03	Lever Switch, Cassette Power (SW451)
17	013-3470-05	Lever Switch, FF
18	013-3558-02	Lever Switch, Tape End
19	015-0232-00	Plunger
20	020-0366-00	DC Motor
21	340-0398-00	Spacer
22	602-0074-00	Belt A
23	602-0075-00	Belt B
24	603-0083-07	Motor Pulley
25	610-0225-00	Guide Roller
26	610-0225-01	Guide Roller
27	610-0226-00	Guide Arm Roller
28	610-0227-01	Eject Roller
29	611-0065-01	Flywheel
30	613-0021-01	Pulley Gear
31	613-0029-00	Loading Gear A
32	613-0030-00	Loading Gear B
33	613-0031-00	Loading Gear C
34	613-0032-00	Loading Gear D
35	613-0033-00	Power Gear
36	630-1511-03	Loading Link
37	630-1513-01	Lock Link
38	630-1514-11	FF Lever
39	630-1515-11	REW Lever
40	630-1518-00	Lock Arm
41	630-1512-01	FF Link B
42	630-1526-00	Replay Link B
43	631-0370-00	Tension Pulley

Ref. No.	Part No.	Description
44	631-0392-04	Cassette Pack Stopper
45	631-0394-00	Cancel Link
46	631-0395-01	SW Link
47	631-0398-00	Eject Link
48	631-0419-00	Clump
49	714-2003-81	Screw
50	714-2360-81	Screw
51	714-2380-81	Screw
52	714-2360-81	Screw
53	714-2604-11	Screw
54	714-2604-81	Screw
55	714-2606-11	Screw
56	716-0347-00	Screw
57	716-0482-01	Screw
58	743-1500-10	E-stop Ring
59	743-2000-10	E-stop Ring
60	744-0006-01	Special E-stop Ring
61	744-0024-01	Special E-stop Ring
62	745-0645-00	Special Washer
63	745-0646-00	Special Washer
64	745-0647-00	Special Washer
65	746-0628-01	Special Washer
66	750-2219-00	Spring
67	750-2220-01	Spring
68	750-2221-01	Spring
69	750-2222-00	Spring
70	750-2223-01	Spring
71	750-2224-01	Spring
72	750-2225-00	Spring
73	750-2226-00	Spring
74	750-2227-00	Spring
75	750-2228-00	Spring
76	750-2229-00	Spring
77	750-2230-01	Spring
78	750-2231-00	Spring
79	750-2232-00	Spring
80	960-3528-00	Motor Assembly
81	746-0730-00	Special Washer

ELECTRICAL PARTS LIST

Ref. No.	Part No.	Description
CHASSIS MISCELLANEOUS		
	4161-71188	Connector with Lead Wire
	4163-701121	Antenna Cord
	5791-6TS01A01	Liquid Crystal Display
	4443-ZZ0666	Connector, Liquid Crystal Display
	4163-701123	Connector with Lead Wire (Includes: FU901, FU902, L901) (Accessory)
LCN1	4163-0312017	Connector with Lead Wire, 3 Pos.
LCN2	4163-0323017	Connector with Lead Wire, 3 Pos.
LCN3	4163-0723017	Connector with Lead Wire, 7 Pos.
LCN4,5	4163-0510017	Connector with Lead Wire, 5 Pos.
LCN6,7	4163-0711017	Connector with Lead Wire, 7 Pos.
LCN8,9,10,11	4163-0411017	Connector with Lead Wire, 4 Pos.
LCN12,13	4163-0613017	Connector with Lead Wire, 6 Pos.
LCN14,15	4163-0513017	Connector with Lead Wire, 5 Pos.
LCN16	4163-0516017	Connector with Lead Wire, 5 Pos.
LCN17	4163-0216018	Connector with Lead Wire, 2 Pos.
LCN18	4163-0920018	Connector with Lead Wire, 9 Pos.
LCN19	4163-0516018	Connector with Lead Wire, 5 Pos.
LCN20	4163-701124	Connector with Lead Wire, 4 Pos.
LCN21	4163-701125	Connector with Lead Wire, 9 Pos.
LCN22	4163-701126	Connector with Lead Wire, 4 Pos.
LCN23	4163-0222018	Connector with Lead Wire, 2 Pos.
LCN871	4163-701132	Connector with Lead Wire, 2 Pos.

PCB-1 MAIN P.C. BOARD

CAPACITORS		
C1	5345-227B0962	220 μ F, \pm 20%, 10V, Electrolytic
C2,4,705,722	5345-107B043	100 μ F, \pm 20%, 10V, Electrolytic
C3,5	5345-477B0962	470 μ F, \pm 20%, 10V, Electrolytic
C7	5345-226C043	22 μ F, \pm 20%, 16V, Electrolytic
C361,508,557,558,561, 562,715,716,717	5345-106C0961	10 μ F, \pm 20%, 16V, Electrolytic
C362,364,505,761	5345-105F0961	1 μ F, \pm 20%, 50V, Electrolytic
C363,714	5345-476C0961	47 μ F, \pm 20%, 16V, Electrolytic
C501,502,512	5359-223541	0.022 μ F, \pm 5%, 100V, Polypropylene
C503,504,551,552	5345-475D0961	4.7 μ F, \pm 20%, 25V, Electrolytic
C553,554	5345-107A0961	100 μ F, \pm 20%, 6.3V, Electrolytic
C555,556	5345-107B0962	100 μ F, \pm 20%, 10V, Electrolytic
C567,568	5345-225F0961	2.2 μ F, \pm 20%, 50V, Electrolytic
C571,572	5359-682541	6800pF, \pm 5%, 100V, Polypropylene
C701,712	5359-103541	0.01 μ F, \pm 5%, 100V, Polypropylene
C702,703	5345-475D043	4.7 μ F, \pm 20%, 25V, Electrolytic
C704	5345-105F043	1 μ F, \pm 20%, 50V, Electrolytic
C708	5345-335F0961	3.3 μ F, \pm 20%, 50V, Electrolytic
C709	5345-226B0961	22 μ F, \pm 20%, 10V, Electrolytic
C711,718	5345-474F0961	0.47 μ F, \pm 20%, 50V, Electrolytic
C719,720	5345-104F0961	0.1 μ F, \pm 20%, 50V, Electrolytic
C721	5345-107C0962	100 μ F, \pm 20%, 16V, Electrolytic
TC701	5371-610	Trimmer Capacitor
INTEGRATED CIRCUITS		
IC361	5652-TA7362P	TA7362P
IC501	5652-TC4066BF	TC4066BF
IC701	5654-D1708G-1	μ PD1708G-011
IC702	5652-TA78L005	TA78L005
IC703	5654-TC4011BP	TC4011BP
IC704	5654-TC4013BP	TC4013BP

Ref. No.	Part No.	Description
TRANSISTORS		
Q1,706	5613-2001(L)	2SC2001(L)
Q2,3,707	5611-966(Y)	2SA966(Y)
Q4,361,557,558,701,703, 709,713,714,715,716, 718,719,729,721,722	5613-2603(F)	2SC2603(F)
Q362,555,556,559,560, 712	5611-1115(F)	2SA1115(F)
Q501,705,708,711	5613-RN1203	RN1203
Q551,552,702	5613-2320L(F)	2SC2320L(F)
Q553,554	5611-999L(F)	2SA999L(F)
Q717	5613-3246(H)	2SC3246(H)
DIODES		
D1,708	5635-RD5R1EB	Zener, RD5.1EB
D2	5635-HZ11B-2L	Zener, HZ11B-2L
D3,361	5632-S5566B	S5566B
D4,5,6,362,363,364,702, 703,704,705,706,707, 709,711,712,713,714, 715,716,717,718,719, 720,721,722	5631-1SS133	1SS133
D366	5635-RD6R2EB	Zener, RD6.2EB
D701	5635-RD10EB	Zener, RD10EB
COILS		
L701	5995-100269	
L702	5995-1R0K82	
L703	5995-221K82	
L704	5995-220K82	
MISCELLANEOUS		
TU701	6114-7132	FM Tuner Assembly
TU702	6110-1	AM Tuner Assembly
X701	5691-00450026	Crystal Osc.
RC701	5212-104J0601	R Composite
SG701	5481-1	Spark Gap
SW701/703/704/705, 706/707/708/709	4431-0909718	Push Switch, Memory, Preset, FM/AM
CN17,23,871	4443-0271119	Connector, 2 Pos.
CN18	4443-0971119	Connector, 9 Pos.
CN19	4443-0571119	Connector, 5 Pos.
CN25	4443-0871121	Connector, 8 Pos.

PCB-2 NAB AMP. P.C. BOARD

CONTROLS		
VR251,252	5101-47370715	47k Ω
CAPACITORS		
C251,252	5359-121541	120pF, \pm 5%, 100V, Polypropylene
C253,254,261,262	5345-106C043	10 μ F, \pm 20%, 16V, Electrolytic
C255,256	5359-332541	3300pF, \pm 5%, 100V, Polypropylene
C257,258	5345-477B0962	470 μ F, \pm 20%, 10V, Electrolytic
C259	5345-226C043	22 μ F, \pm 20%, 16V, Electrolytic
C263,271	5345-227B0962	220 μ F, \pm 20%, 10V, Electrolytic
C265,266	5359-102541	1000pF, \pm 5%, 100V, Polypropylene
C267,268	5359-223541	0.022 μ F, \pm 5%, 100V, Electrolytic
TRANSISTORS		
Q251,252	5613-2320L(F)	2SC2320L(F)
Q253,254	5611-999L(F)	2SA999L(F)
Q255,256	5611-RN2203	RN2203
Q257,263,264,265,266	5613-2603(F)	2SC2603(F)
Q259,260,261,262	5611-1115(F)	2SA1115(F)
Q268	5613-RN1203	RN1203

Ref. No.	Part No.	Description
L251,252	COILS 5995-223256	

PCB-3 MSS/MECHA CONTROL P.C. BOARD

CAPACITORS		
C201	5345-108C046	1000 μ F, \pm 20%, 16V, Electrolytic
C203	5345-476B043	47 μ F, \pm 20%, 10V, Electrolytic
C204	5345-106C043	10 μ F, \pm 20%, 10V, Electrolytic
C205	5345-104F043	0.1 μ F, \pm 20%, 50V, Electrolytic
C206	5345-475D043	4.7 μ F, \pm 20%, 25V, Electrolytic
INTEGRATED CIRCUITS		
IC201	5654-TC4042BP	TC4042BP
IC202	5652-M51143L	M51143L
TRANSISTORS		
Q201	5613-2001(L)	2SC2001(L)
Q202,205	5611-RN2203	RN2203
Q203,207	5613-RN1203	RN1203
Q204	5611-950(Y)	2SA950(Y) or 2SA950(O)
Q206	5611-1115(F)	2SA1115(F)
DIODES		
D201,202,203,204,207	5631-1SS133	1SS133
D205	5635-RD5R1EB	Zener, RD5.1EB
D206	5641-KB265	Varistor
COILS		
L201	5995-391269	

PCB-4 BUFFER AMP. P.C. BOARD

CAPACITORS		
C10	5345-107C0962	100 μ F, \pm 20%, 16V, Electrolytic
C11	5345-108C046	1000 μ F, \pm 20%, 16V, Electrolytic
C401,403	5345-477B0962	470 μ F, \pm 20%, 10V, Electrolytic
C405,406,407,408	5345-475D043	4.7 μ F, \pm 20%, 25V, Electrolytic
C409,410,413,414	5345-226C043	22 μ F, \pm 20%, 16V, Electrolytic
C455	5345-476B043	47 μ F, \pm 20%, 10V, Electrolytic
C456	5345-476C0961	47 μ F, \pm 20%, 16V, Electrolytic
TRANSISTORS		
Q401,402,405,406	5613-2603(F)	2SC2603(F)
Q403,404,407,408	5611-1115(F)	2SA1115(F)
Q409,410,411,412	5613-2878(B)	2SC2878(B)
DIODES		
D10,11	5632-S5566B	S5566B

PCB-5 IF MPX P.C. BOARD

CONTROLS		
VR101	5101-33170715	330 Ω
VR151	5101-22370715	22k Ω
VR152	5101-47370715	47k Ω
VR153	5101-10370715	10k Ω

Ref. No.	Part No.	Description
CAPACITORS		
C104,118	5345-475D043	4.7 μ F, \pm 20%, 25V, Electrolytic
C107	5369-223244	0.022 μ F, \pm 20%, 25V, Semiconductor
C114,167,168	5345-105F043	1 μ F, \pm 20%, 50V, Electrolytic
C115	5345-104F043	0.1 μ F, \pm 20%, 50V, Electrolytic
C151,152,153,176	5359-271541	270pF, \pm 5%, 100V, Polypropylene
C154	5345-107B043	100 μ F, \pm 20%, 10V, Electrolytic
C155,156,173	5359-103541	0.01 μ F, \pm 5%, 100V, Polypropylene
C157	5345-226C043	22 μ F, \pm 20%, 16V, Electrolytic
C158	5359-222541	2200pF, \pm 5%, 100V, Polypropylene
C159	5359-332541	3300pF, \pm 5%, 100V, Polypropylene
C160,161	5359-681541	680pF, \pm 5%, 100V, Polypropylene
C162	5359-122541	1200pF, \pm 5%, 100V, Polypropylene
C164	5359-682541	6800pF, \pm 5%, 100V, Polypropylene
C165	5345-476B043	47 μ F, \pm 20%, 10V, Electrolytic
C169	5359-333541	0.033 μ F, \pm 5%, 100V, Polypropylene
C170	5345-335F043	3.3 μ F, \pm 20%, 50V, Electrolytic
C171	5345-227B0962	220 μ F, \pm 20%, 10V, Electrolytic
C172	5359-473541	0.047 μ F, \pm 5%, 100V, Polypropylene
C174,175	5359-102541	1000pF, \pm 5%, 100V, Polypropylene
INTEGRATED CIRCUITS		
IC101	5652-LA1140	LA1140
IC151	5652-LA2110	LA2110
IC152	5652-LA3376	LA3376
TRANSISTORS		
Q101	5613-2058(N)	2SC2058(N)
Q102,103	5613-RN1203	RN1203
Q104,151	5611-1115(F)	2SA1115(F)
DIODES		
D101,102	5631-1SS133	1SS133
D103	5635-RD5R1EB	Zener, RD5.1EB
D151	5631-1K34A	1K34A
D152	5635-RD4R7EB	Zener, RD4.7EB
COILS		
L101	5995-221269	
L102	5995-100269	
TRANSFORMERS		
T101	5572-00111	
T102	5572-00112	
MISCELLANEOUS		
CF101	5671-7151A	Ceramic Filter
L151,152	5214-70	LC Composite

PCB-6 VOLUME P.C. BOARD

VR601/603/604/605/606/ 607/608	5112-1040117	Control, 100k Ω , Volume, Balance, Bass, Treble
-----------------------------------	--------------	--------------------------------------------------------

PCB-7 FADER CONTROL P.C. BOARD

VR651/652	5110-104012	Control, 100k Ω , Fader
-----------	-------------	--------------------------------

PCB-8 CASSETTE MECHANISM SWITCH P.C. BOARD

C601	5369-104244	Capacitor, 0.1 μ F, \pm 20%, 25V, Semiconductor
Q601	5613-2236(Y)	Transistor, 2SC2236(Y)
SW451	013-2690-03	Lever Switch, Cassette Power

Ref. No.	Part No.	Description
PCB-9 DOLBY NR P.C. BOARD		
RESISTORS		
R305,306	5178-222481	2.2k Ω , \pm 2%, 1/6W, Metal
R307,308	5178-112481	1.1k Ω , \pm 2%, 1/6W, Metal
R311,312	5178-304481	300k Ω , \pm 2%, 1/6W, Metal
CAPACITORS		
C301,302	5345-475D043	4.7 μ F, \pm 20%, 25V, Electrolytic
C303,304	5359-821541	820pF, \pm 5%, 100V, Polypropylene
C305,306,313,314	5345-106C043	10 μ F, \pm 20%, 16V, Electrolytic
C307,308	5359-333741	0.033 μ F, \pm 2%, 100V, Polypropylene
C309,310	5359-182541	1800pF, \pm 5%, 100V, Polypropylene
C311,312	5359-472741	4700pF, \pm 2%, 100V, Polypropylene
C321	5345-226-10	22 μ F, \pm 20%, 10V, Electrolytic
C322,325,327	5345-227-10	220 μ F, \pm 20%, 100V, Electrolytic
C323	5345-107-10	100 μ F, \pm 20%, 10V, Electrolytic
INTEGRATED CIRCUITS		
IC301	5652-TA7719P	TA7719P
TRANSISTORS		
Q723	5613-2878(B)	2SC2878(B)
PCB-10 LAMP P.C. BOARD		
LAMP871	5731-1407170	Lamp, 14V, 40mA
PCB-11 SWITCHES P.C. BOARD		
SW852,853,854	4431-A017162	Push Switch, Seek, Tuning Up/Down
LAMP851	5731-1407170	Lamp, 14V, 40mA
PCB-12 LCD P.C. BOARD		
SW801,802,804,805	4431-A017163	Push Switch, Eject, Dolby NR, Music Search/Mono, Tape/LOCAL-DX selector
LAMP801,802,803	5731-1407170	Lamp, 14V, 40mA

PACKAGE

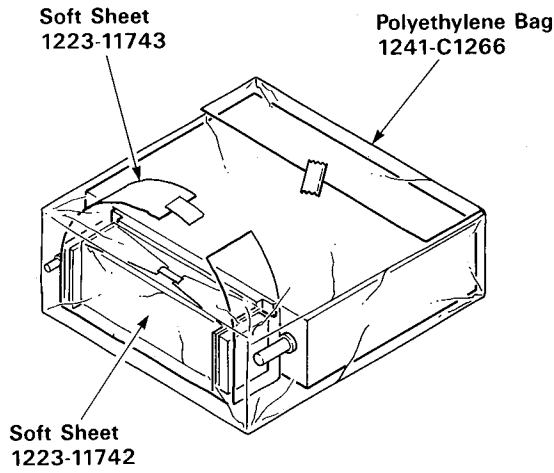

- *Accessory**
 Boss (10mm) (1 pc.)
 Flat Washer (4 pcs.)
 Hex. Nut (4 pcs.)
 Bolt (2 pcs.)
 Tapping Screw (1 pc.)
 Spring Washer (1 pc.)

